

***BIOMIMÉTISME ET AÉRONAUTIQUE:
Pourquoi rugueux, flexible et accidenté
est mieux que lisse, rigide et régulier ?***

A. Bottaro (DICCA, Université de Gênes)

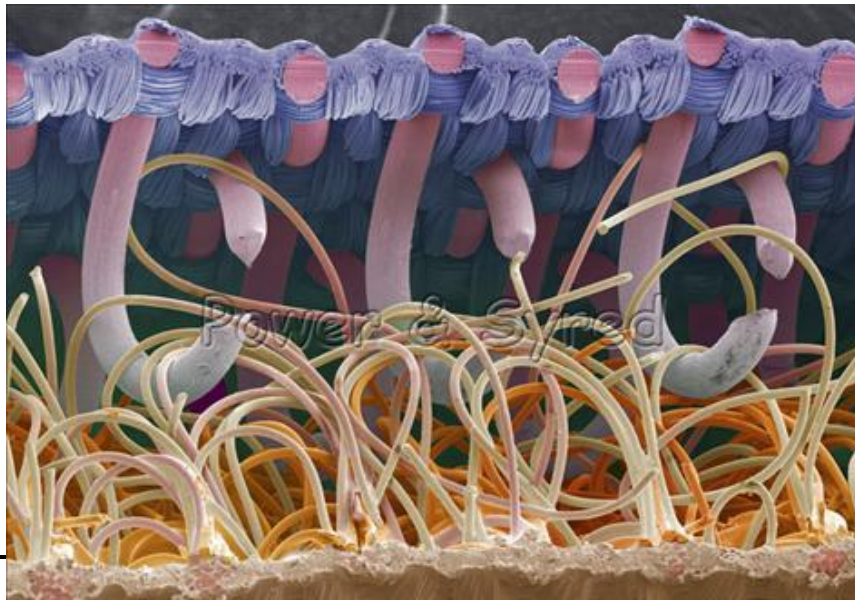



***BIOMIMETISME:
ça démarre avec le velcro ...***

Georges de Mestral, 1941

Petit déjeuner du RTRA, Toulouse, 6 june 2012





***BIOMIMÉTISME:
pas seulement le velcro !!!***



Focus: passive/active flow control

Known techniques of passive/active flow control:

- **Injection of micro-bubbles and/or polymers**
- **Riblets**
- **Compliant walls**
- **Viscosity modifier**
- **Vortex generators**
- **...**

Less known techniques of passive/active flow control:

- Butterfly and moth wings microstructure

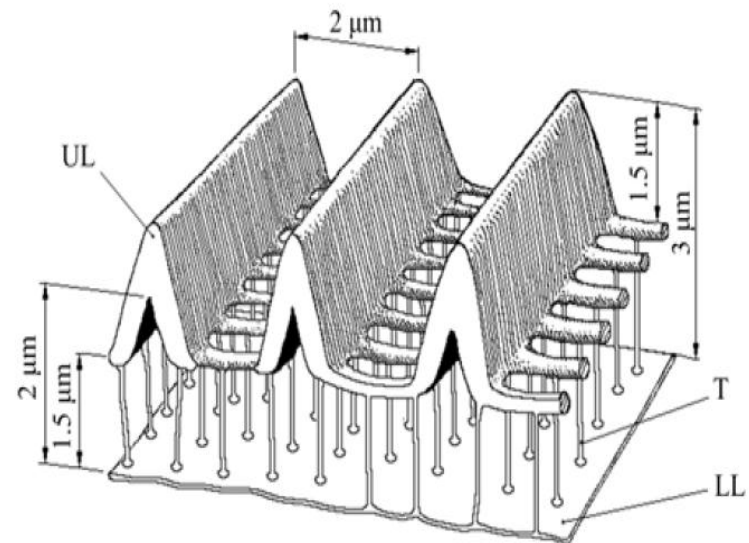
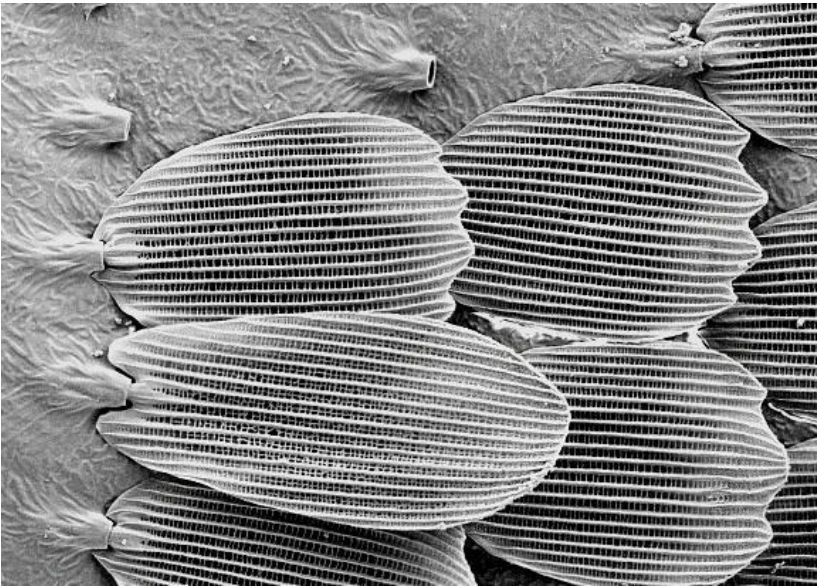

Left: electron microscope image of butterfly scales.

Right: perspective view (with dimensions) with details of a scale.

UL: upper lamina; LL: lower lamina; T: trabecula.

Less known techniques of passive/active flow control:

- Shark skin paint!

The coating that reduces drag (Fraunhofer, Bremen)

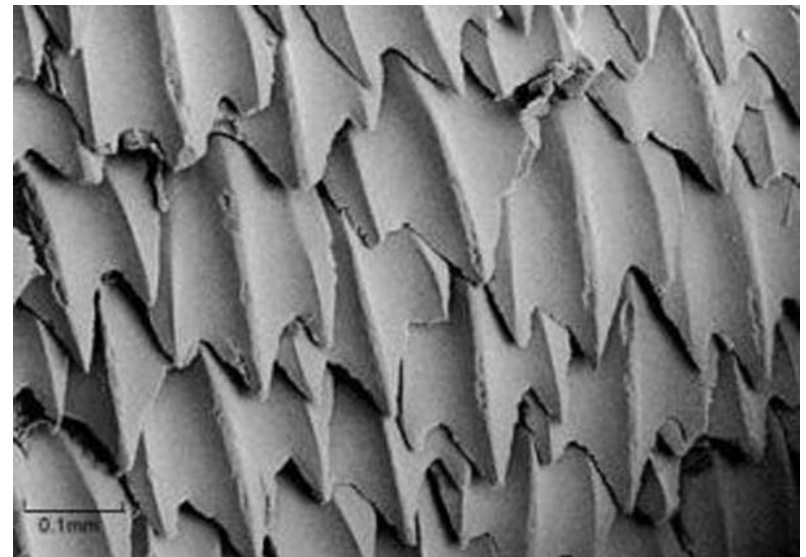
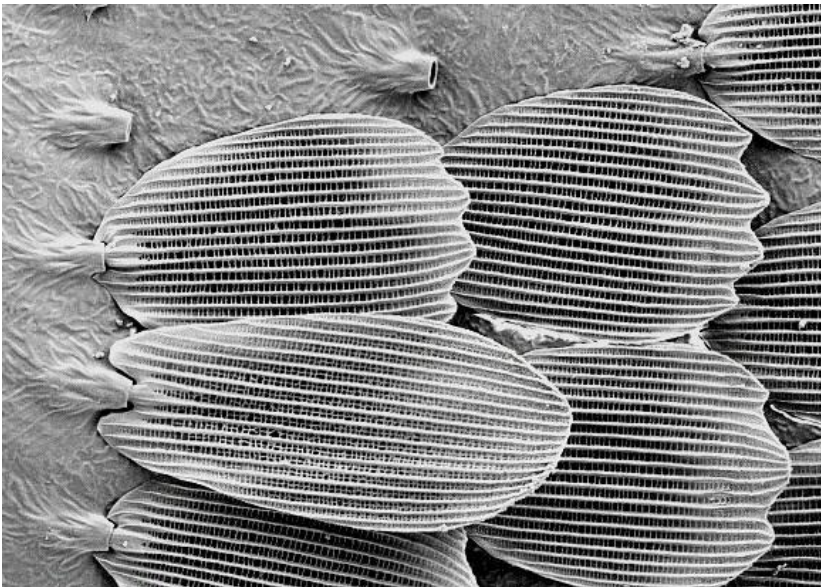

How can we increase lift over a streamlined body at incidence by a **passive technique?**

How can we reduce pressure drag behind a solid bluff body by a **passive** technique?

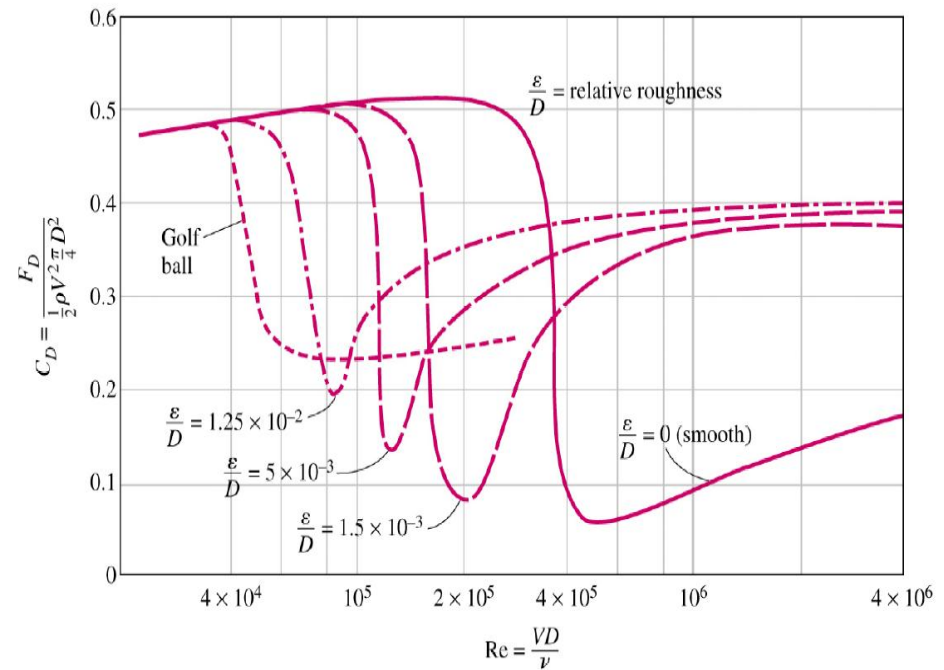
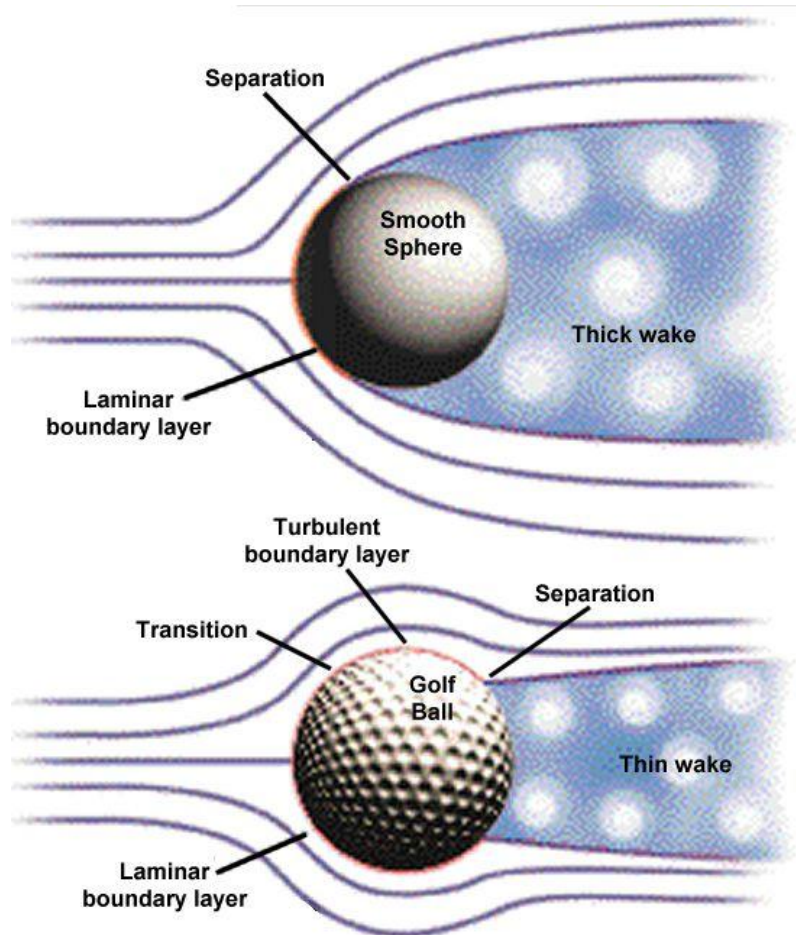

Less known techniques of passive/active flow control:



sea otter
(*loutre de mer*)

Passive, compliant hairy coating

How can we increase lift over a streamlined body at incidence by a **passive** technique?

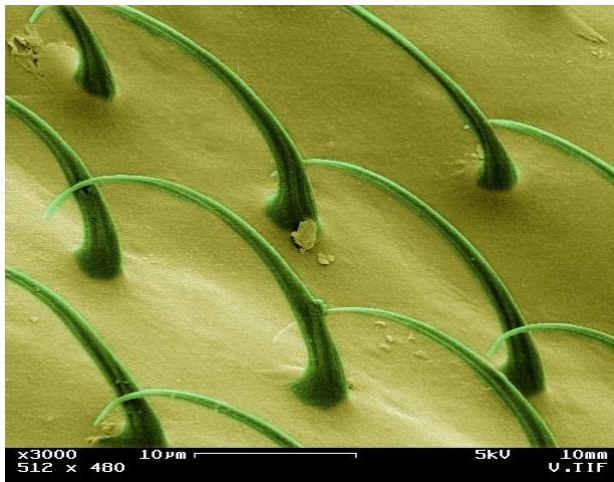
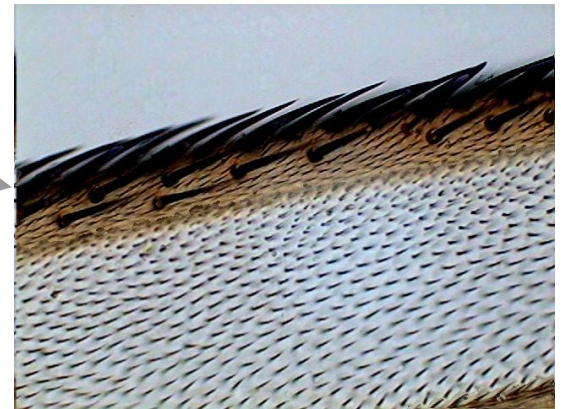
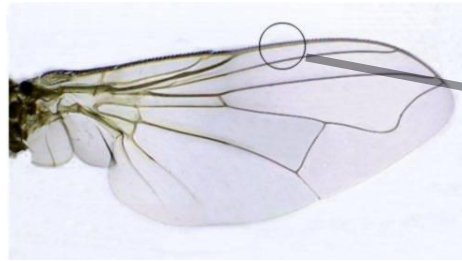

How can we increase lift over a streamlined body at incidence by a **passive** technique?



How can we increase lift over a streamlined body at incidence by a **passive** technique?



Coverts have also a
aerodynamic role ...

How can we increase lift over a streamlined body at incidence by a **passive** technique?

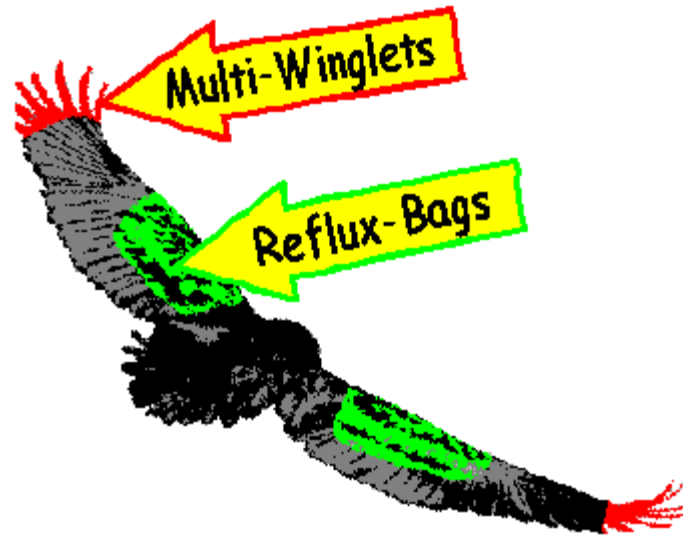

Prof. Ingo Rechenberg, TU Berlin

<http://www.bionik.tu-berlin.de/institut/xs2vogel.html>

How can we increase lift over a streamlined body at incidence by a **passive** technique?

aerofoil with silk flaps

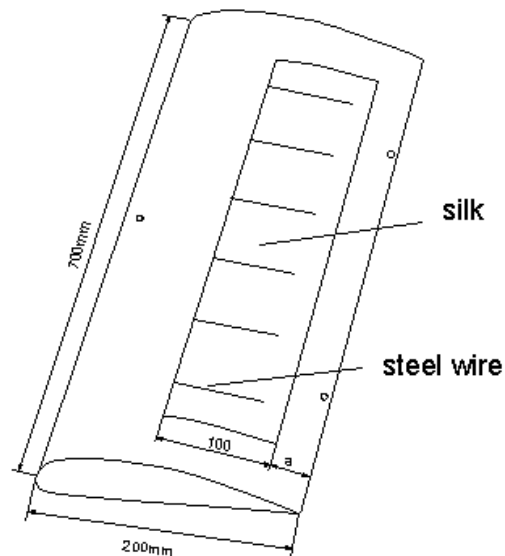

flow visualisation

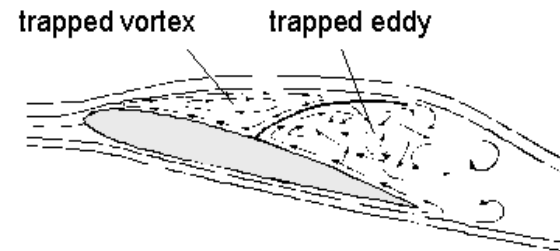

Prof. Ingo Rechenberg, TU Berlin

<http://www.bionik.tu-berlin.de/institut/xs2vogel.html>

Wind tunnel tests in Genova

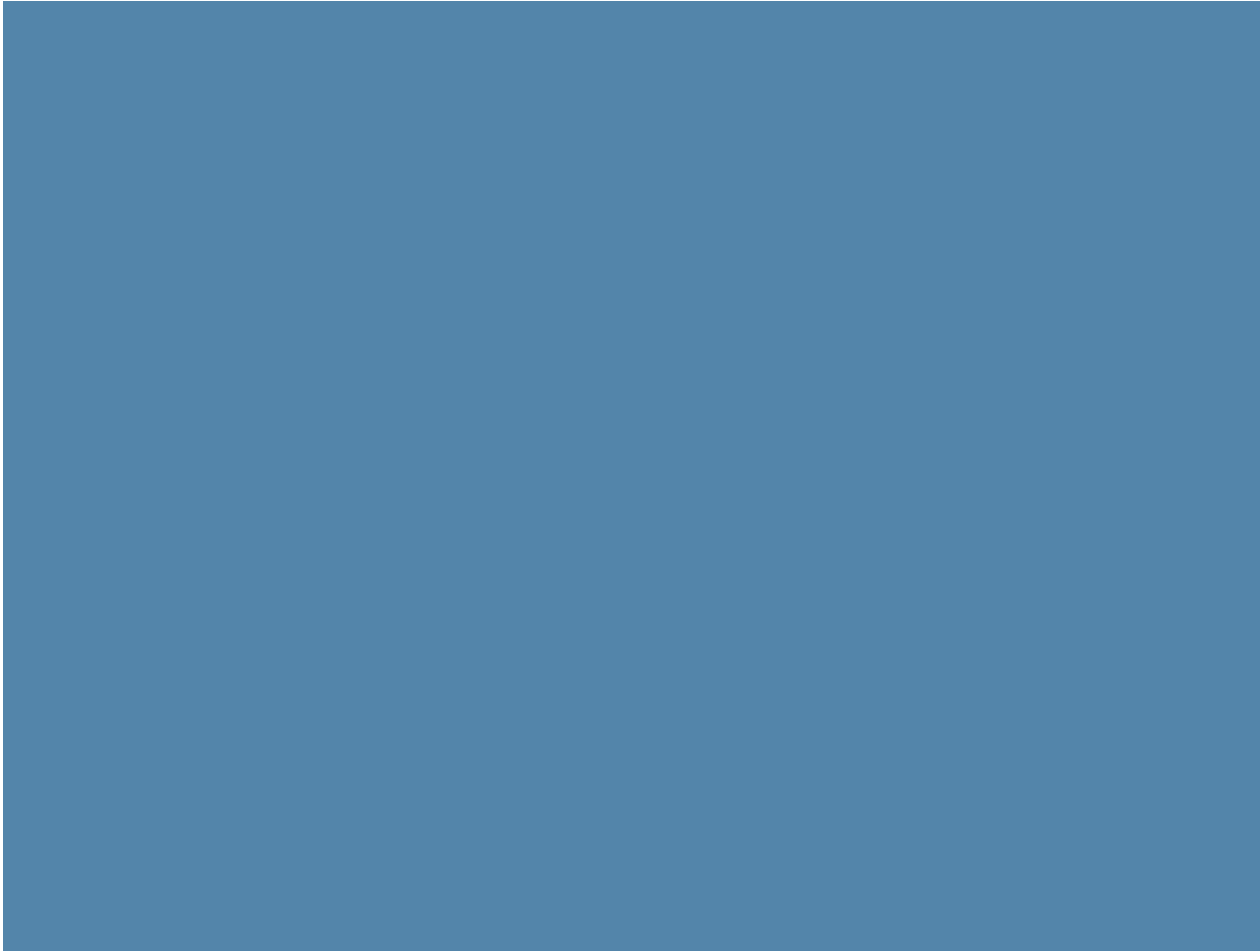

F. Negrello, Engineering Diploma work, 2010

Wind tunnel tests in Genova

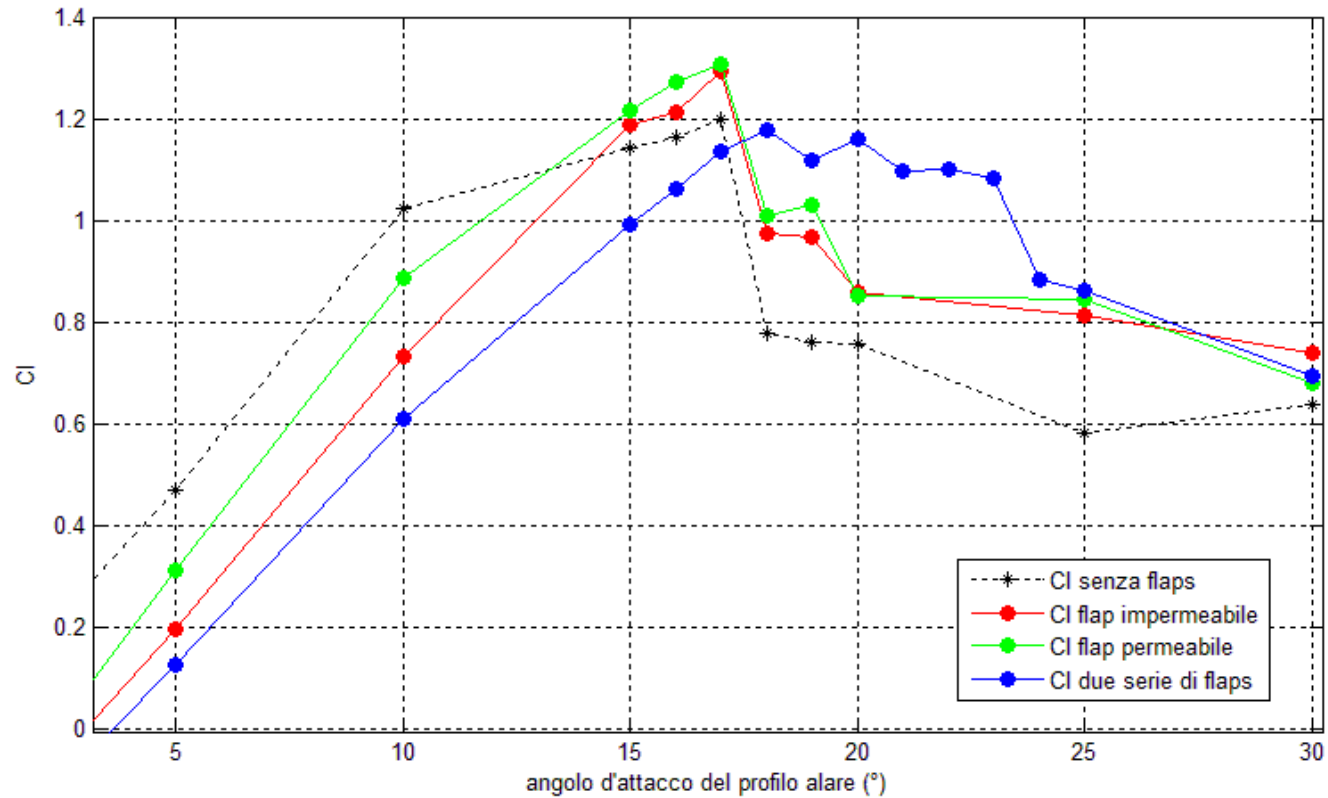

How can we increase lift over a streamlined body at incidence by a **passive** technique?

silk flaps

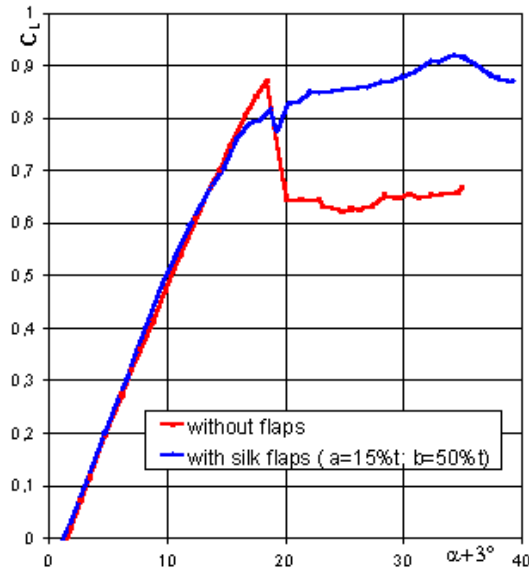

**Flexible, porous flaps
delay stall ...**

Prof. Ingo Rechenberg, TU Berlin

<http://www.bionik.tu-berlin.de/institut/xs2vogel.html>

GOAL: instead of a single flexible flap, let's model a continuous *hairy/feathery* coating to affect lift and drag

Numerical challenges

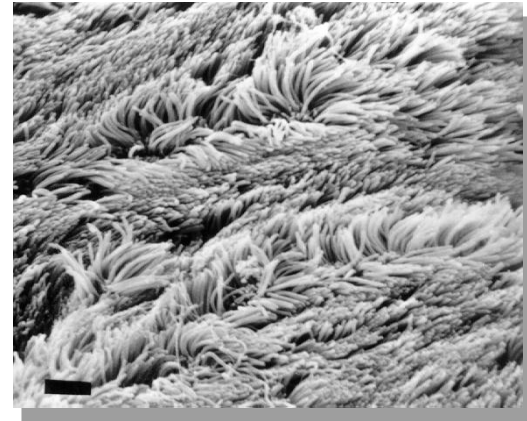

- **Model** mechanical properties of **biological surfaces**
- Structures with **large displacements** and **large rotations**
- Interaction between **multiple structures**

Coupling between a layer of oscillating densely packed structures and a unsteady separated boundary layer

The initial configuration

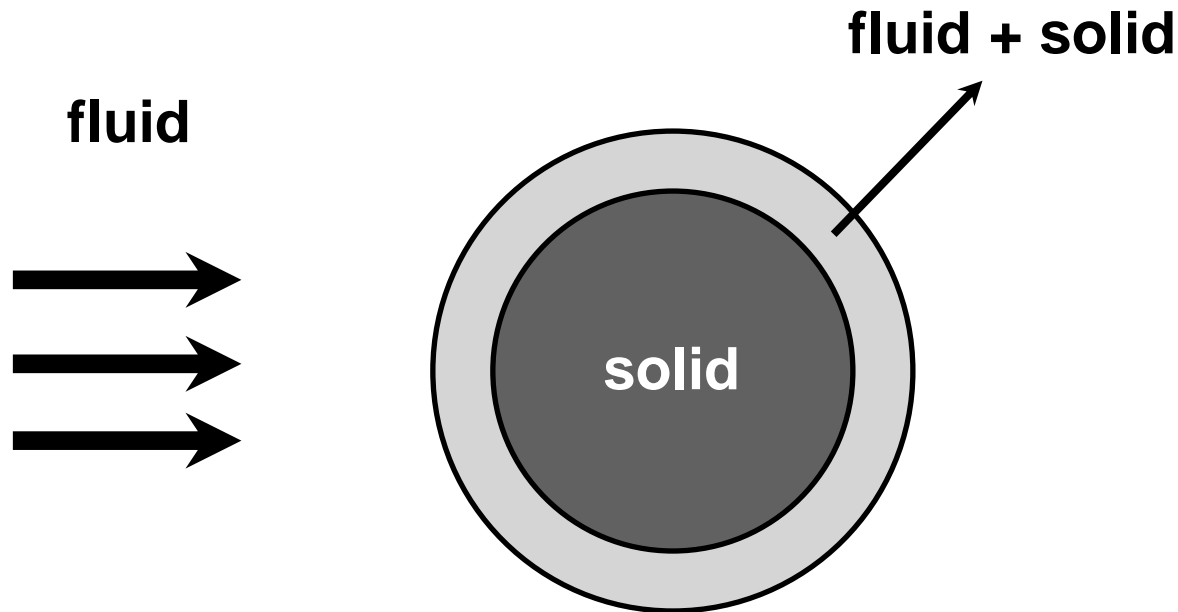

Circular cylinder, $Re=200$

Model of the layer?

Porous, anisotropic and compliant

Case 1: bare cylinder

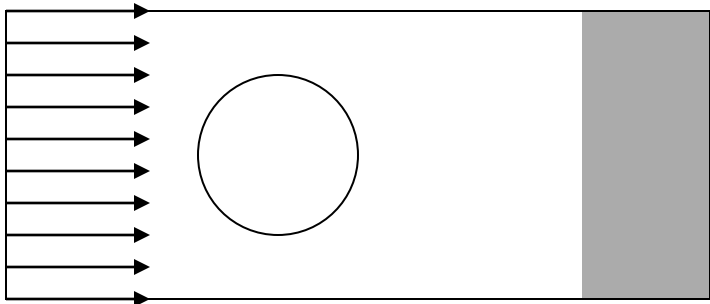
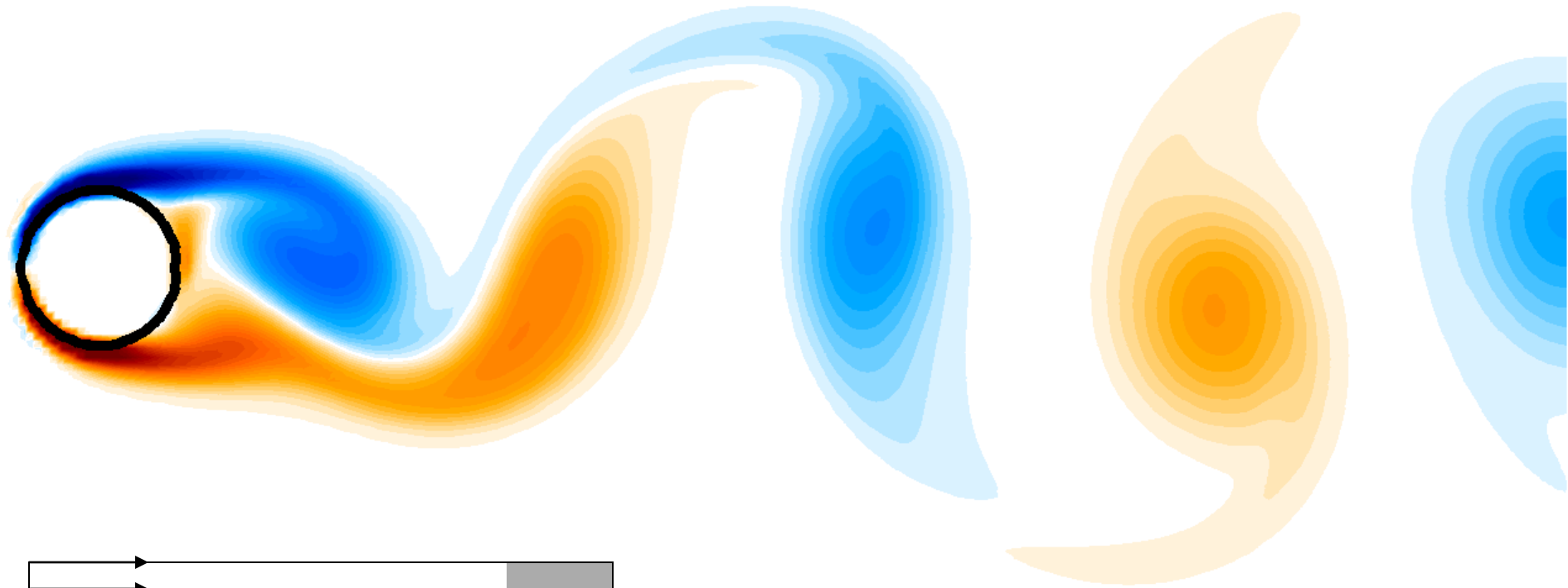

Case 2: rigid wall-normal hair

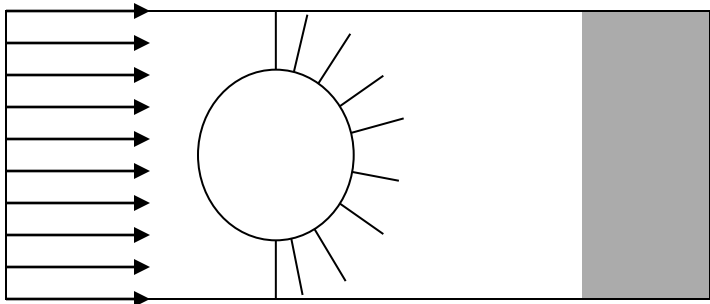
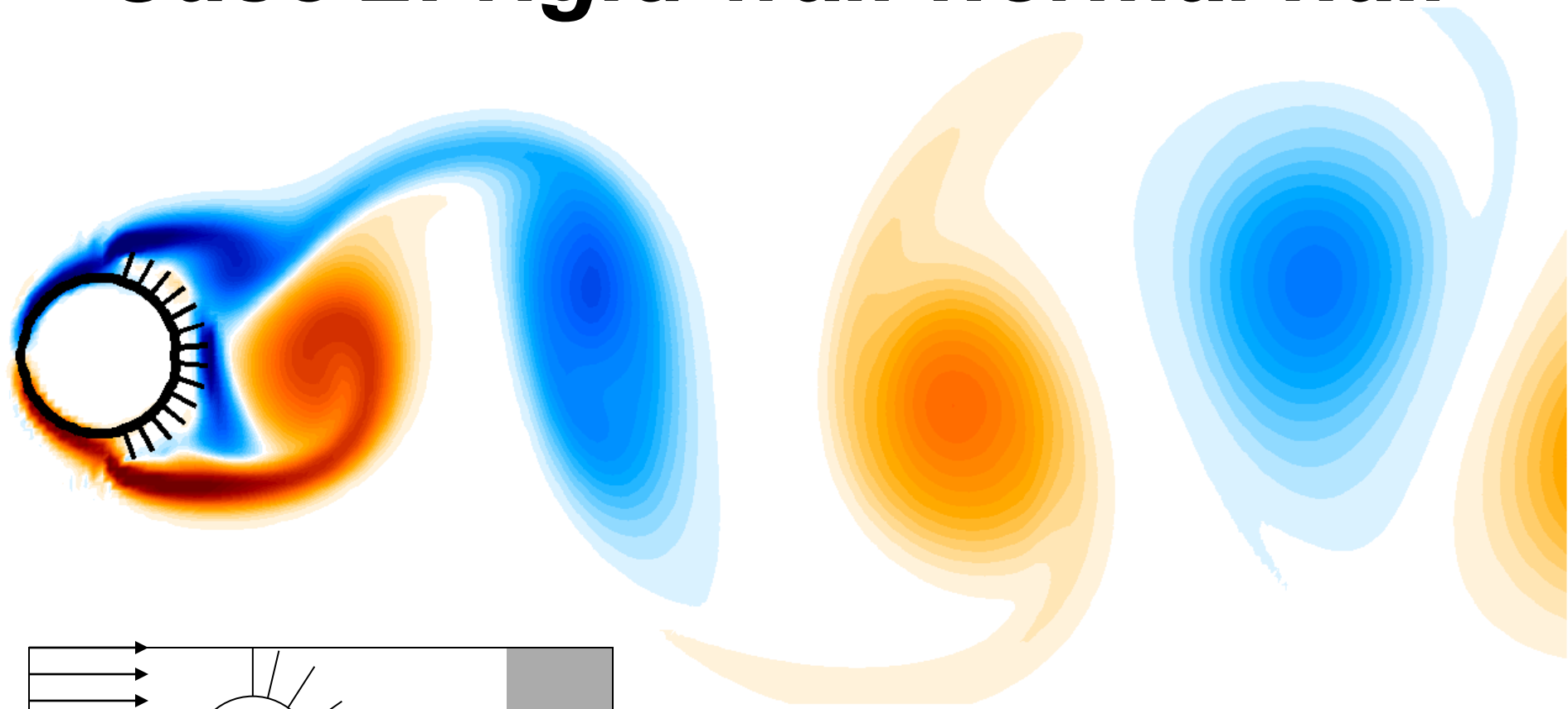

Case 3: rigid longitudinal hair

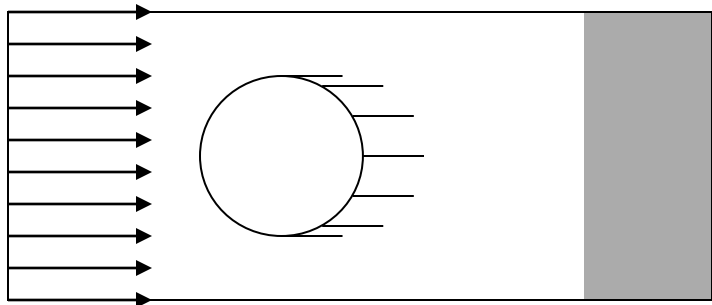
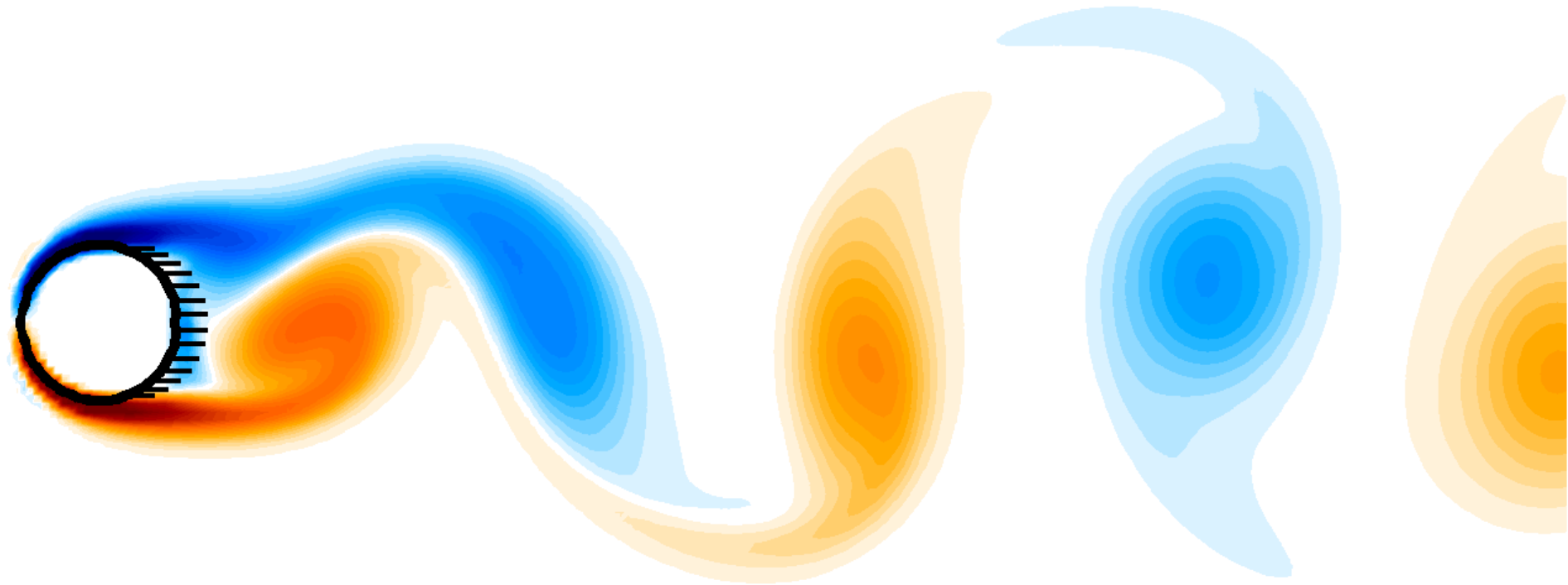

Case 4: moving hair

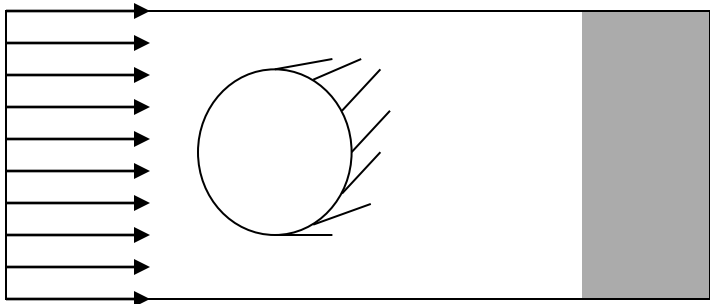
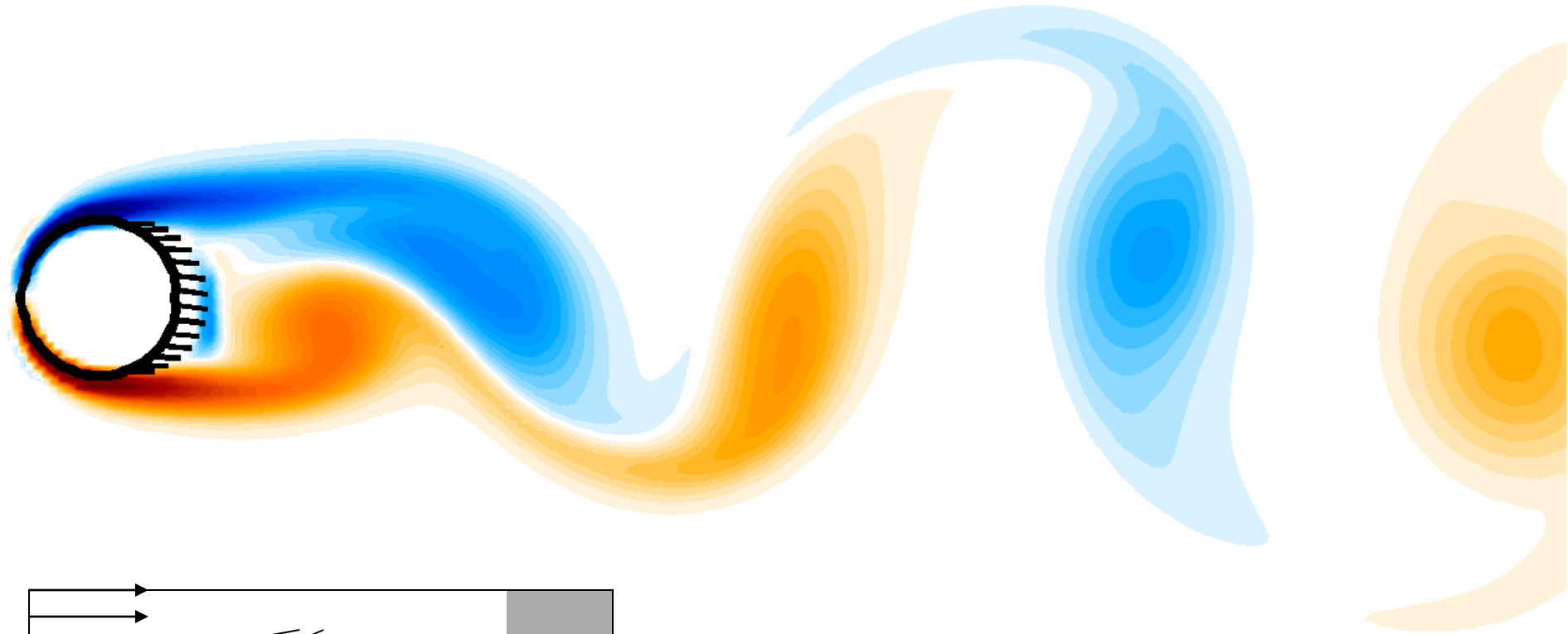

$$T_{fluid} \approx 4 T_{structure}$$

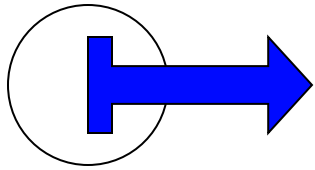

Drag

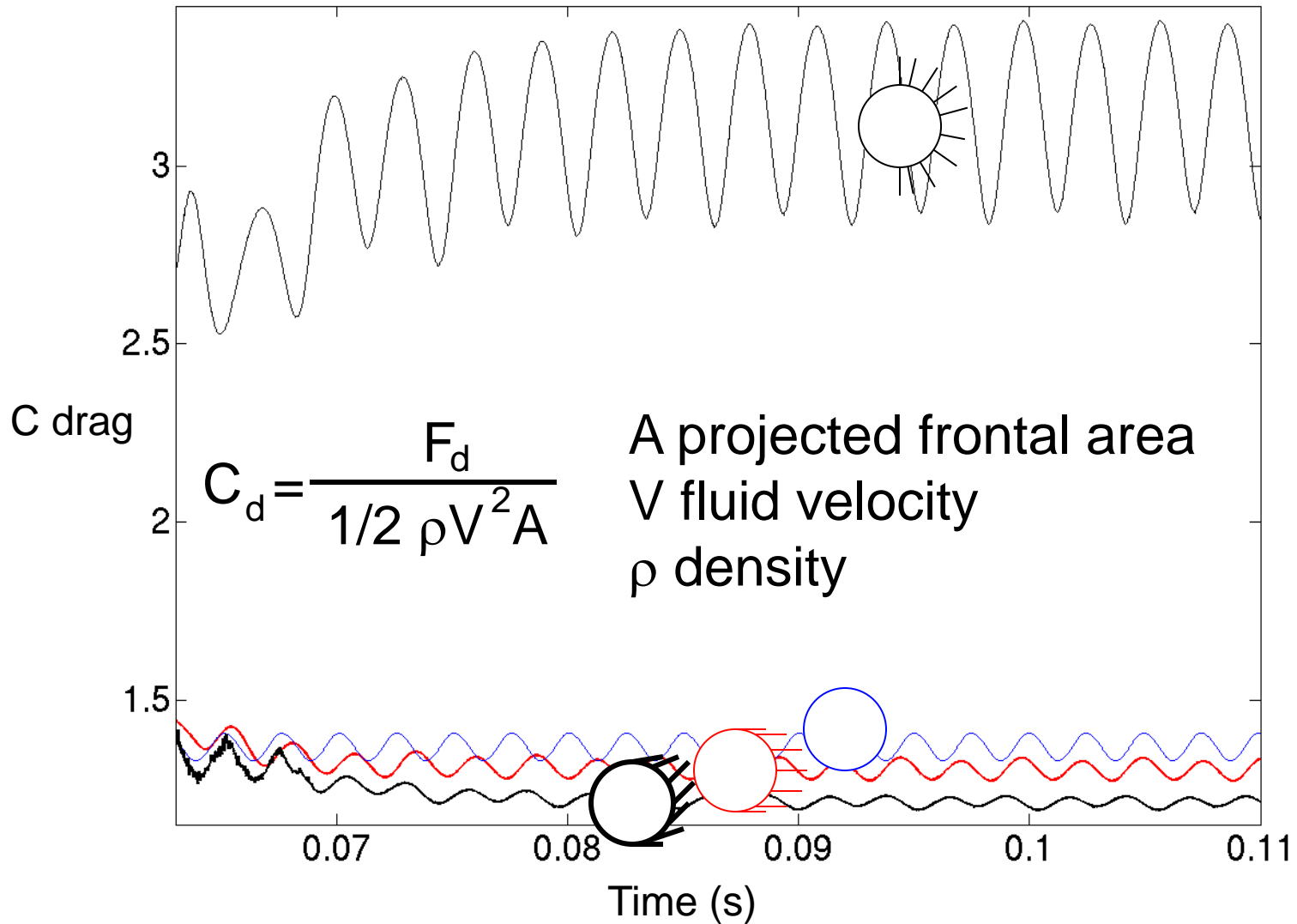

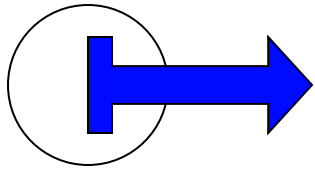

Drag (ctd.)

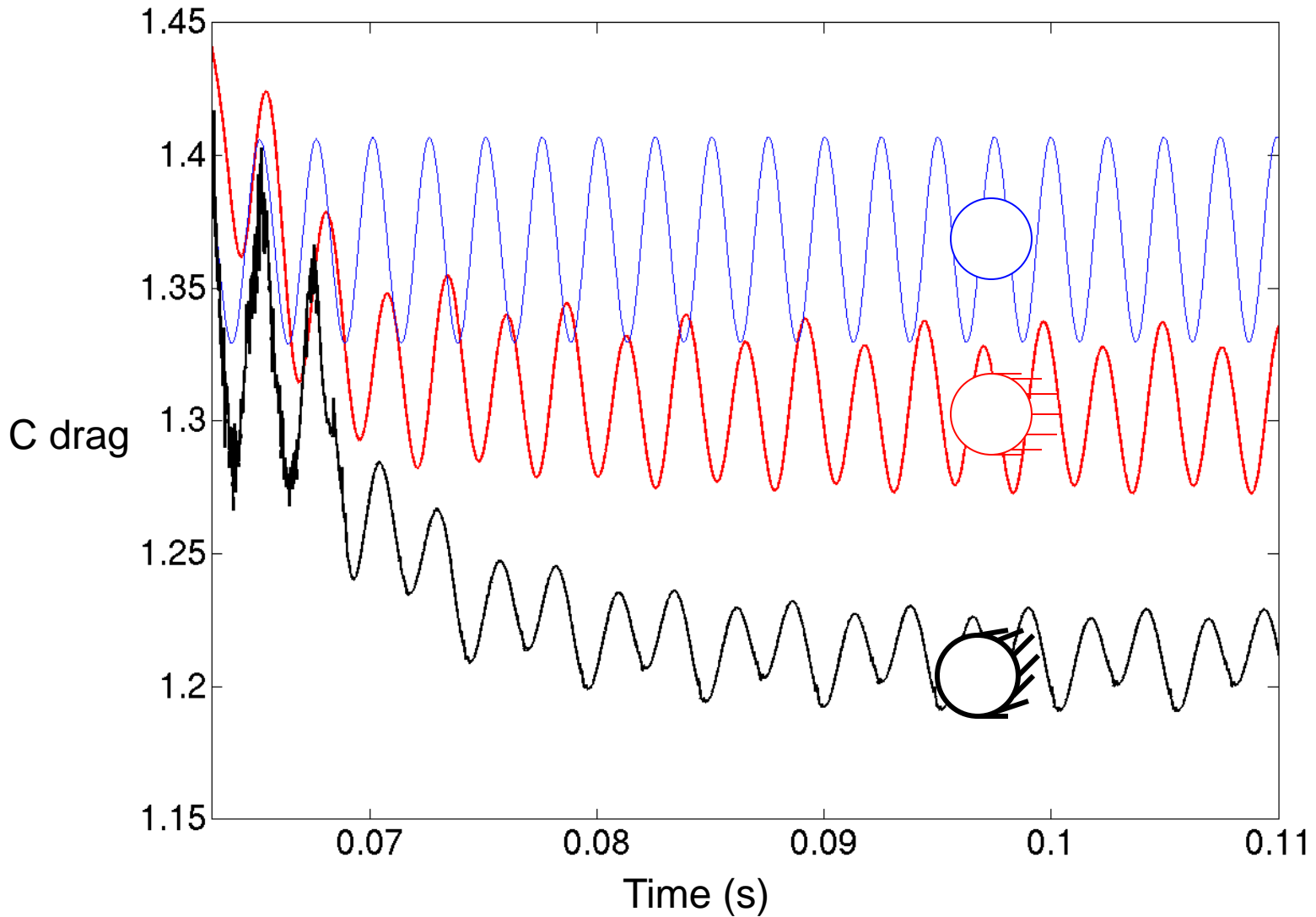

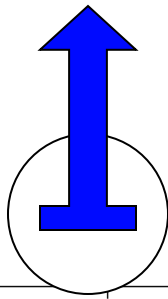

Lift

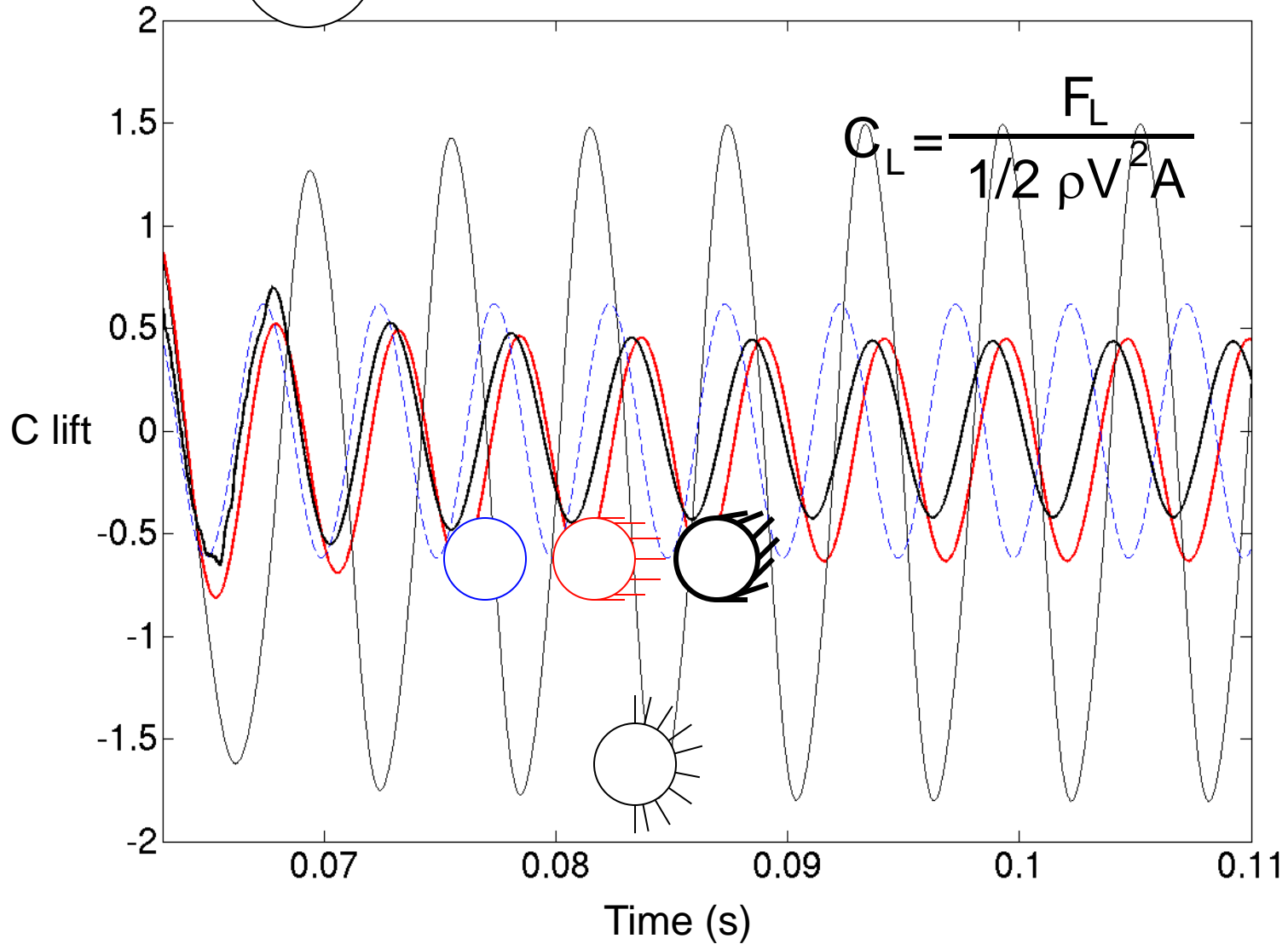

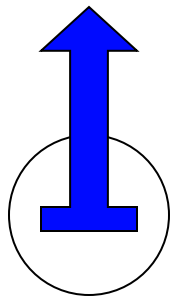

Lift (ctd.)

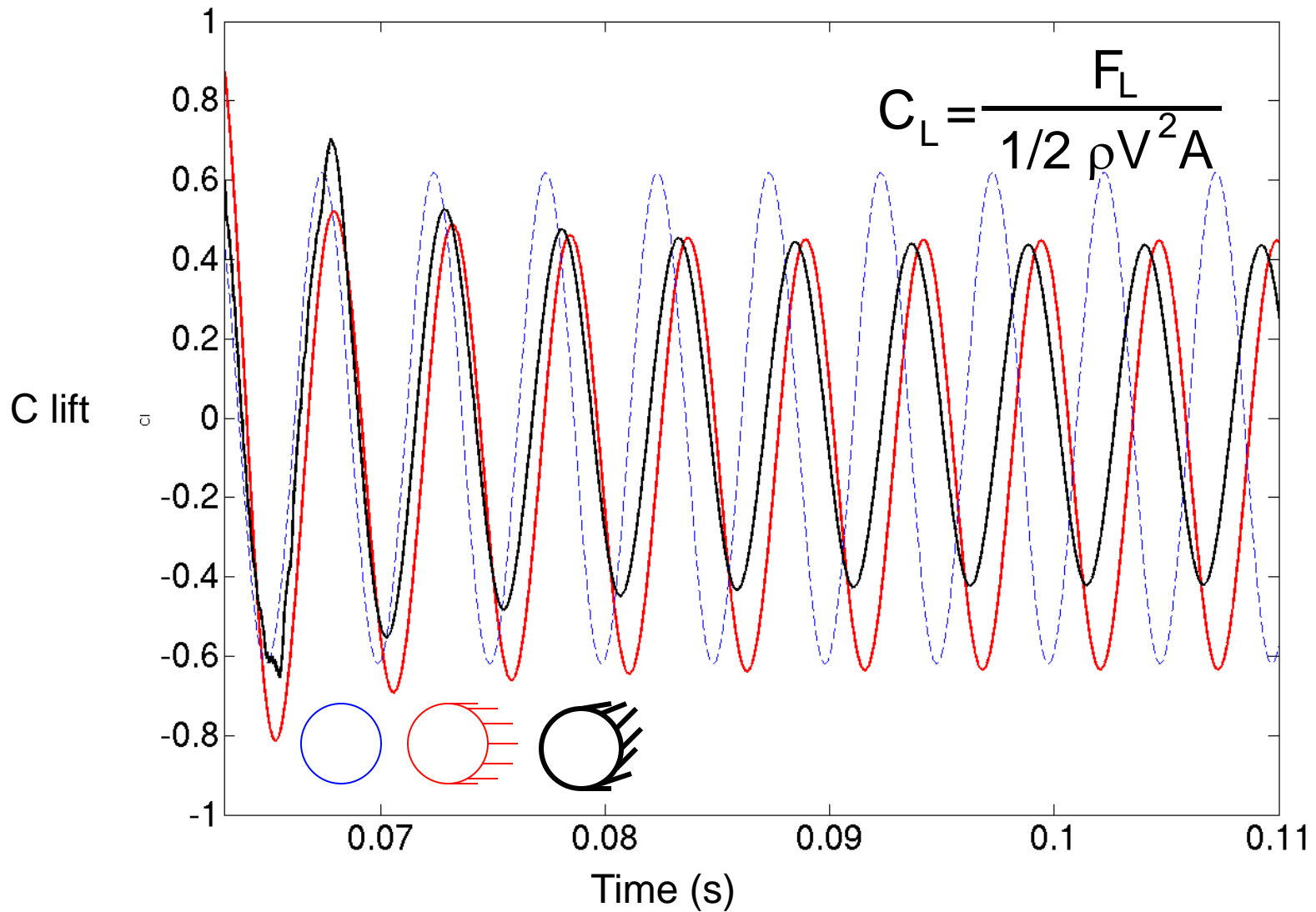

Aerodynamic performances

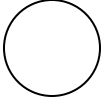
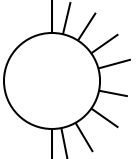
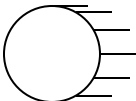
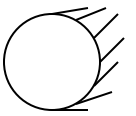
		Cd	Cd'	Cl'	St
Case 1		1.3689 (1.39;1.356)	0.0274	0.4381	0.199 (0.199;0.198)
Case 2		3.1464	0.1943	1.1376	0.1946
Case 3		1.3035	0.0207	0.3839	0.1916
Case 4		1.2109	0.012	0.3008	0.1661

(Bergmann et al. Phys. Fluids 2005 ; He et al J. Fluid Mech. 2000)

Aerodynamic perf.(ctd.)

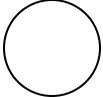
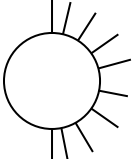
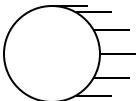
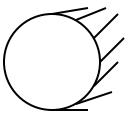
		Cd	Cd'	Cl'	St
Case 1		ref	ref	ref	ref
Case 2		+130%	+608%	+160%	-2.21%
Case 3		-4.78%	-24.54%	-12.37%	-3.71%
Case 4		-11.54%	-56.09%	-31.34%	-16.53%

Physical mechanism

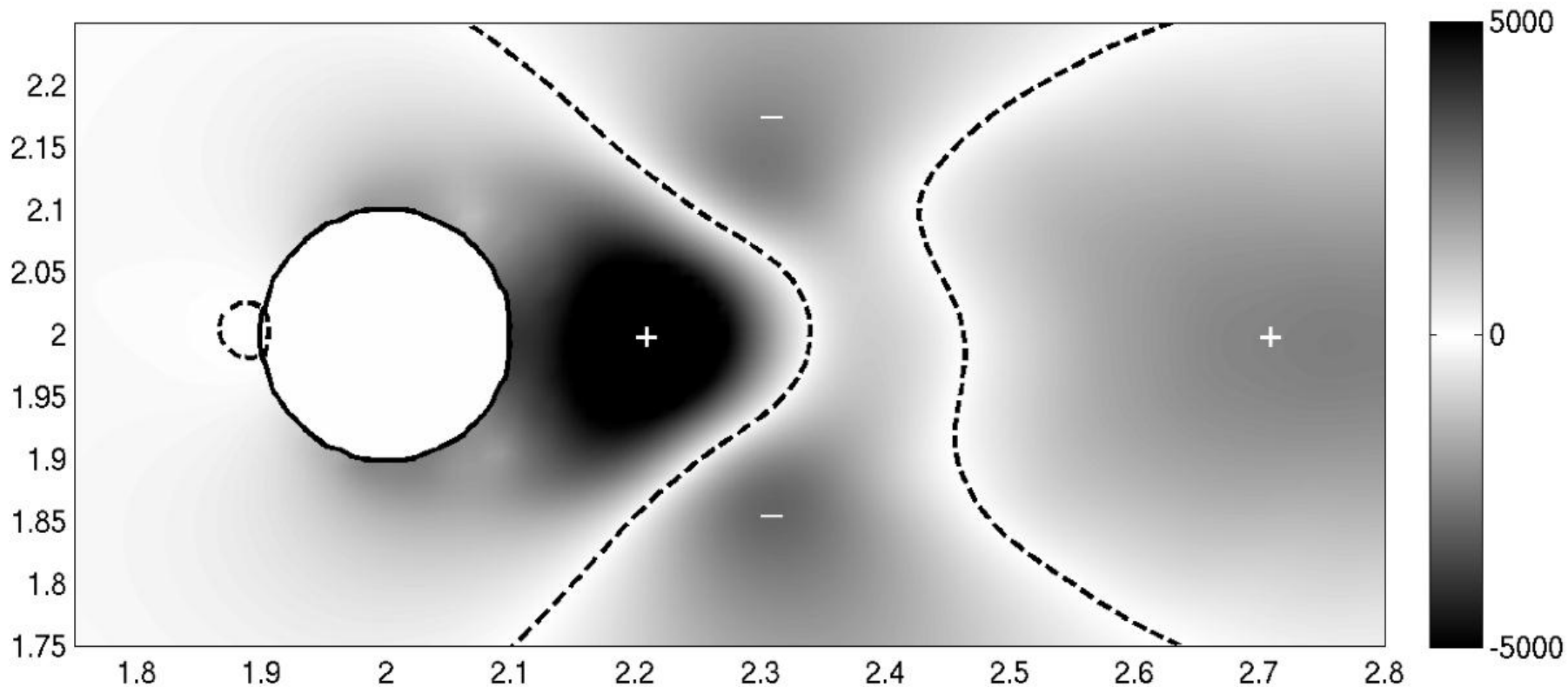

Difference of time-averaged pressure field

$$\langle P \text{ with hair} \rangle - \langle P \text{ ref} \rangle$$

Physical mechanism

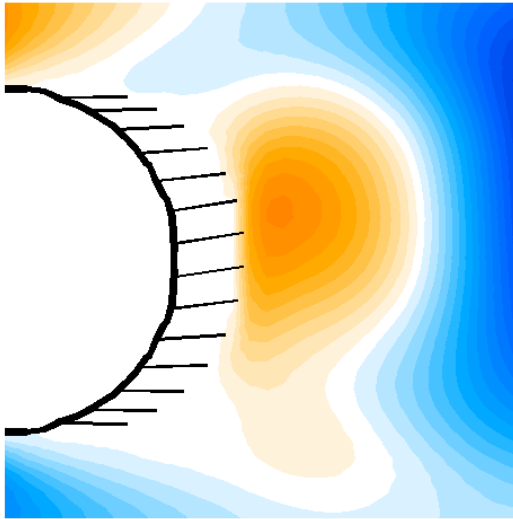

Contours of vertical velocity

Movements of *reference* cilia

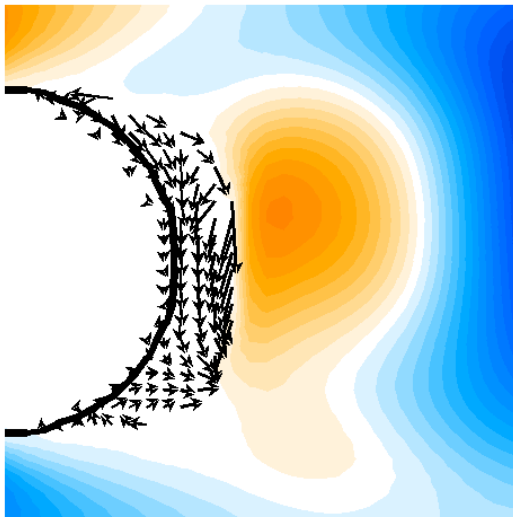

Contours of vertical velocity

Force field

The hairy layer counteracts
flow separation

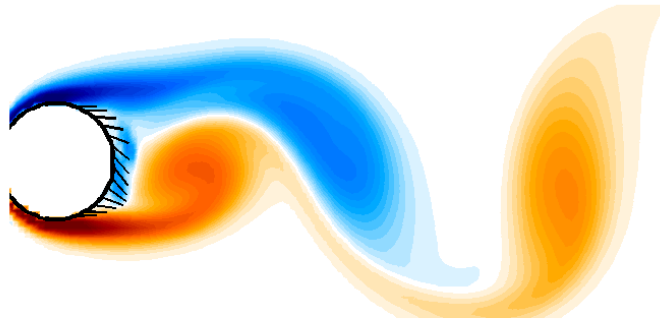

***Optimal* self-adaptive hairy layer**

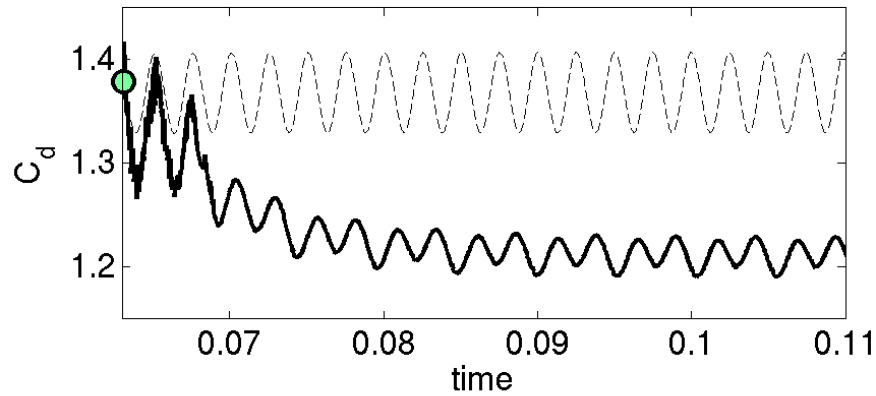

15% drag reduction

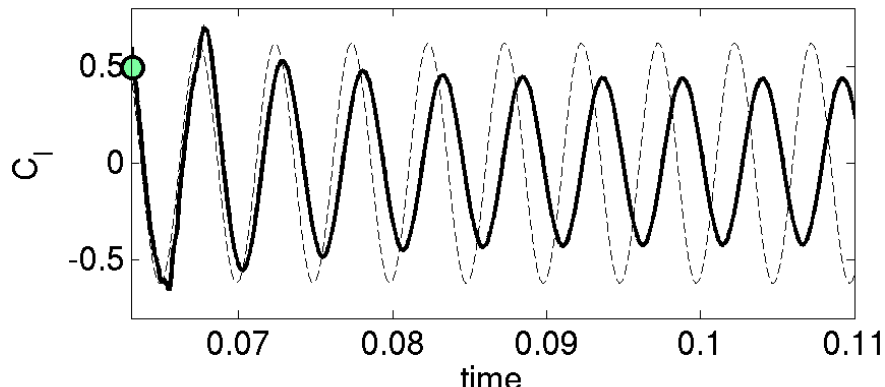

40% reduction in lift fluctuations

Reducing pressure drag:

- ✓ Simulations show a reduction of pressure drag on a cylinder for a unsteady laminar flow ($Re = 200$).
- ✓ The motion of the hairy structures can improve aerodynamic performances
- ✓ The structural parameters of the actuators have been optimised
- ✓ Immediate perspectives concern flexible filaments and turbulent configurations; possible applications to small underwater vehicles and to UAV/MAV (in the aeronautical field)

In fact, a **single** flexible filament can do much already!!

In fact, a **single** flexible filament can do much already!!

time = 264.55 L = 3.00

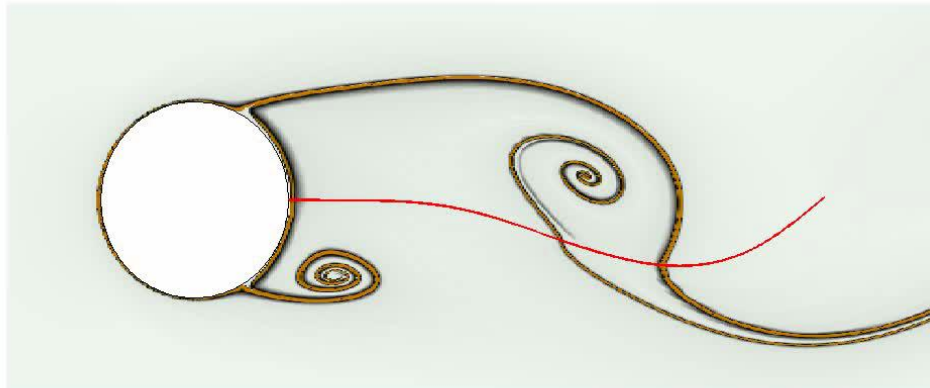

time = 315.05 L = 1.50



Bagheri *et al.*, **PRL**, 2012 (submitted)

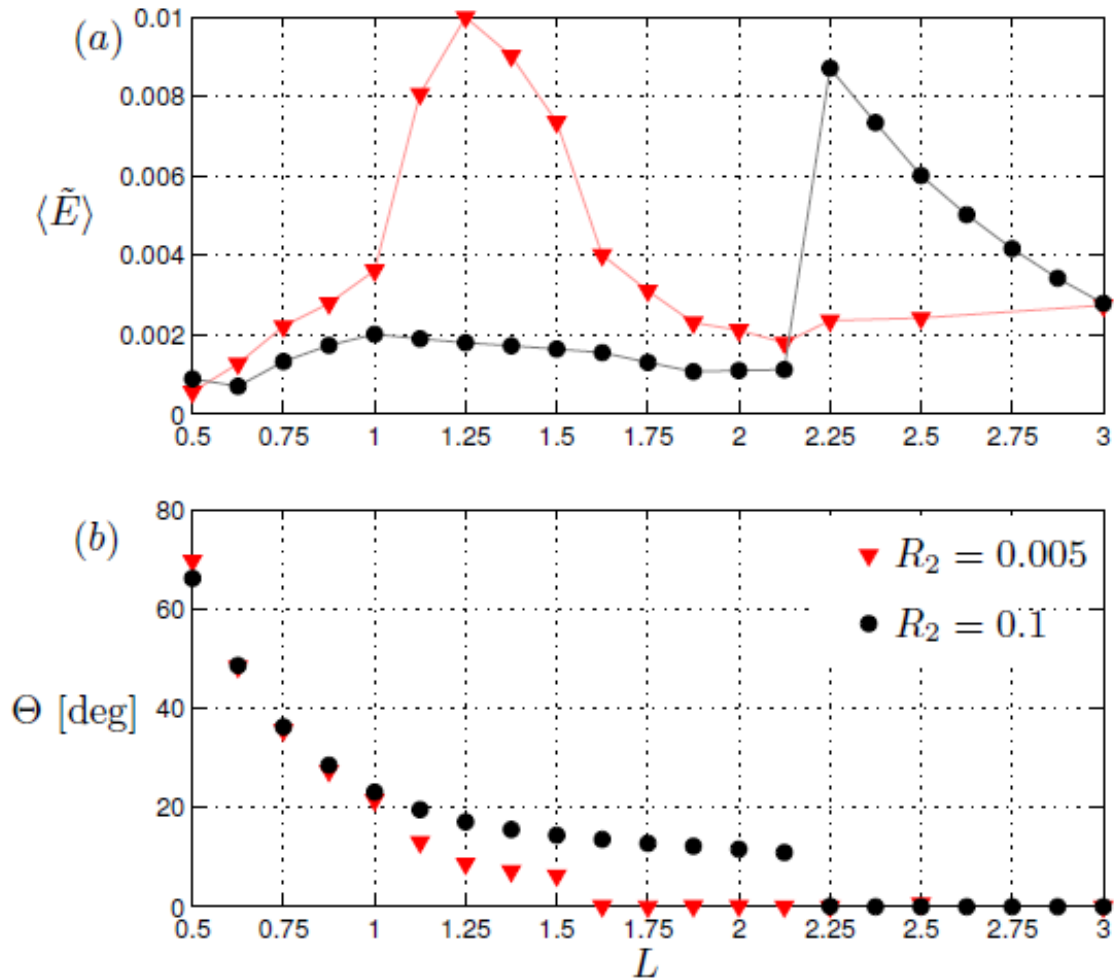

A **symmetry-breaking bifurcation** occurs when vortices and structures resonate ...

L	R_2	C_d	C_l	f_c	y_m
0.0		1.36 ± 0.01	0.00 ± 0.34	0.164	
1.5	0.005	1.32 ± 0.08	0.18 ± 0.28	0.159	0.16 ± 0.43
3.0	0.005	1.28 ± 0.06	0.00 ± 0.23	0.157	0.00 ± 0.64
1.5	0.100	1.23 ± 0.05	0.21 ± 0.24	0.145	0.37 ± 0.13
3.0	0.100	1.24 ± 0.08	0.00 ± 0.32	0.139	0.00 ± 0.54

increasing $R_2 \rightarrow$ increased rigidity of the structure

Hairfoils

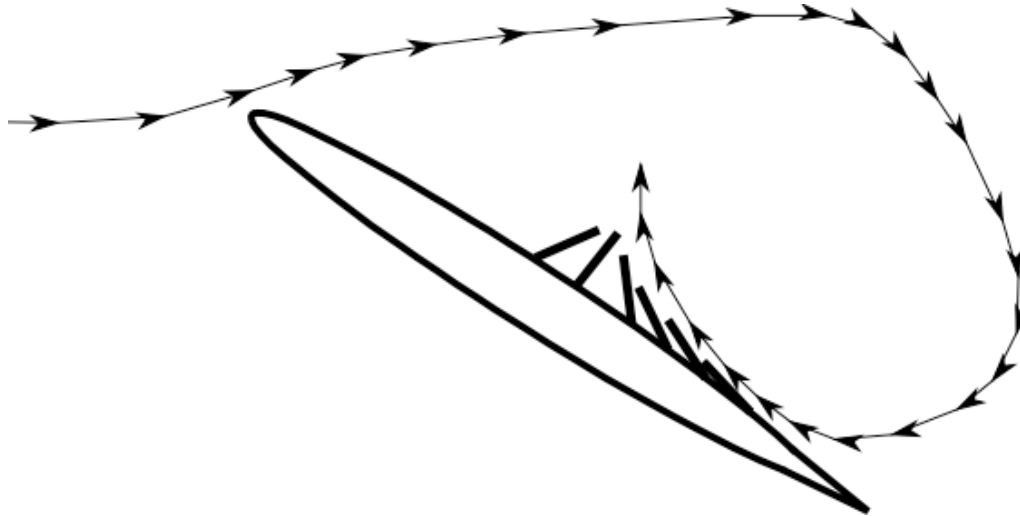

Consider a **h**airfoil: the control elements (the “feathers”) must be placed in the position of largest *sensitivity* to achieve an effect

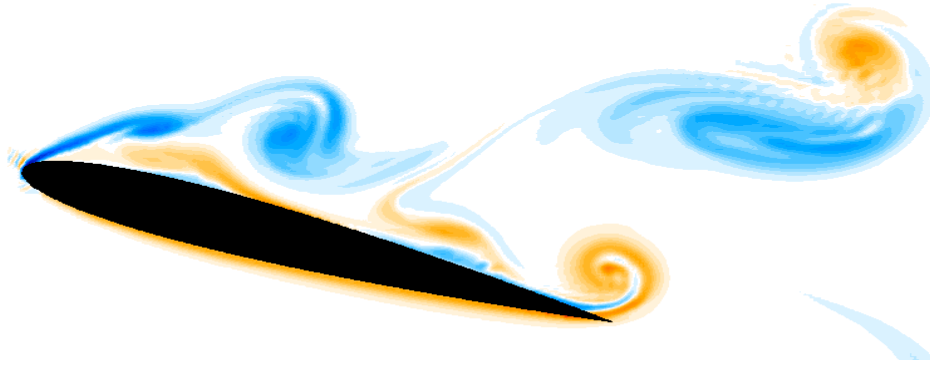

NACA0012

$\alpha = 18^\circ$

$Re = 10^4$

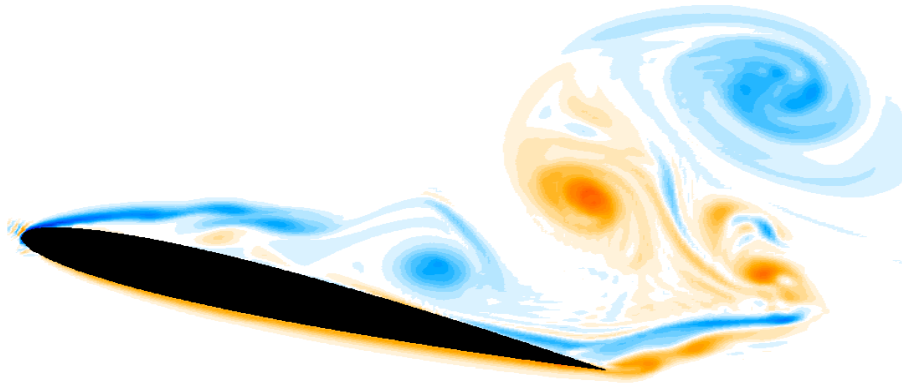

$\alpha = 15^\circ$

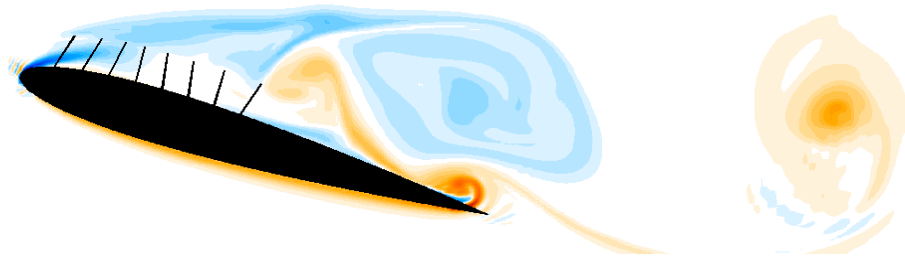

$$\alpha = 18^\circ$$

$$\rho_{\text{feathers}} = 890 \text{ Kg/m}^3 \text{ (keratin)}$$

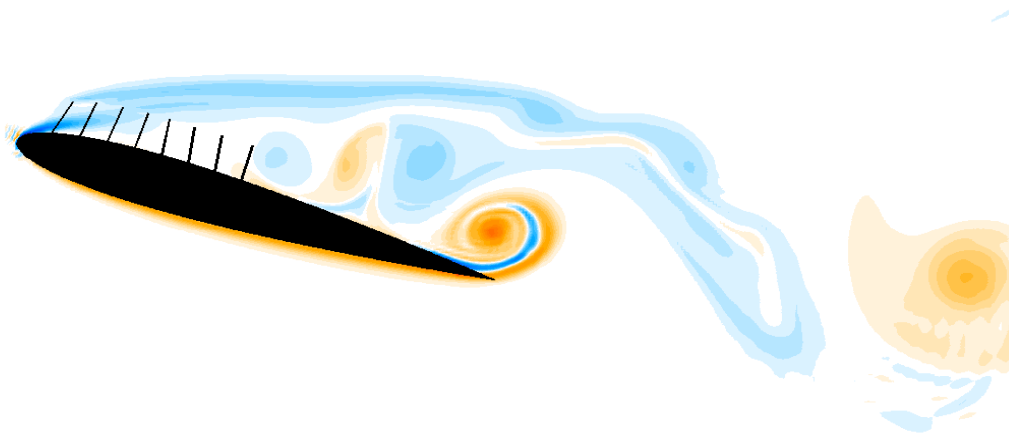

$$\alpha = 18^\circ$$

Summary of runs

$$\alpha = 15^\circ$$

$$\langle C_D \rangle = 0.284 \quad \langle C_L \rangle = 0.579$$

$T_{fluid} = 0.5 T_{structure}$	+ 1.35%	- 13%
$T_{fluid} = T_{structure}$	+ 2 %	- 10%
$T_{fluid} = 2 T_{structure}$	+ 3%	- 9%
$T_{fluid} = 4 T_{structure}$	- 0.2 %	+ 2.5%
$T_{fluid} = 8 T_{structure}$	-7 %	- 11%

Results are similar when $\alpha = 18^\circ$, except that now $\langle C_L \rangle$ increases the most when $T_{fluid} = 2 T_{structure}$

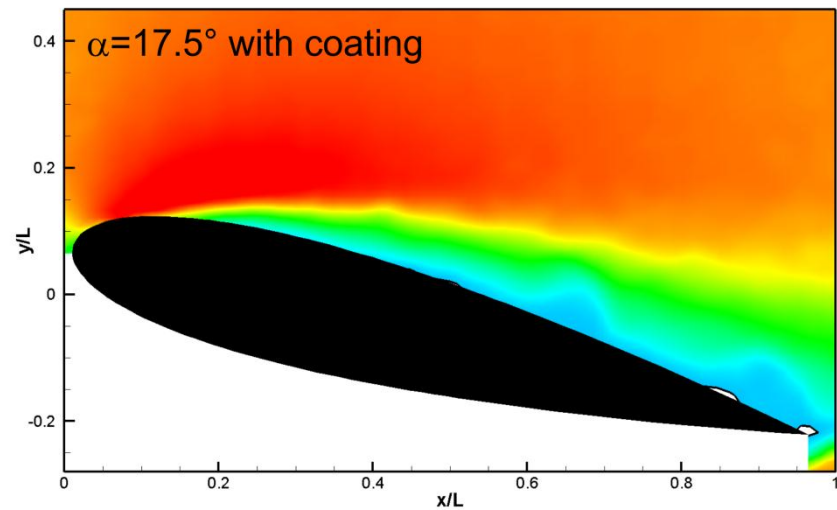
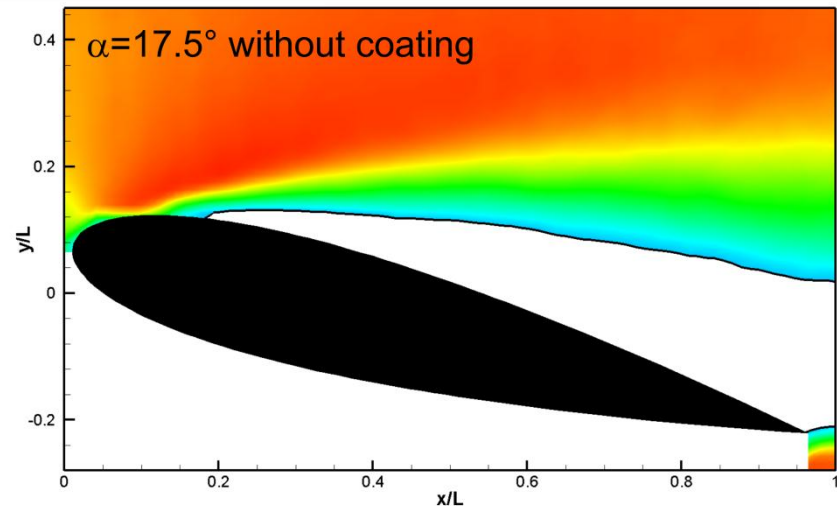
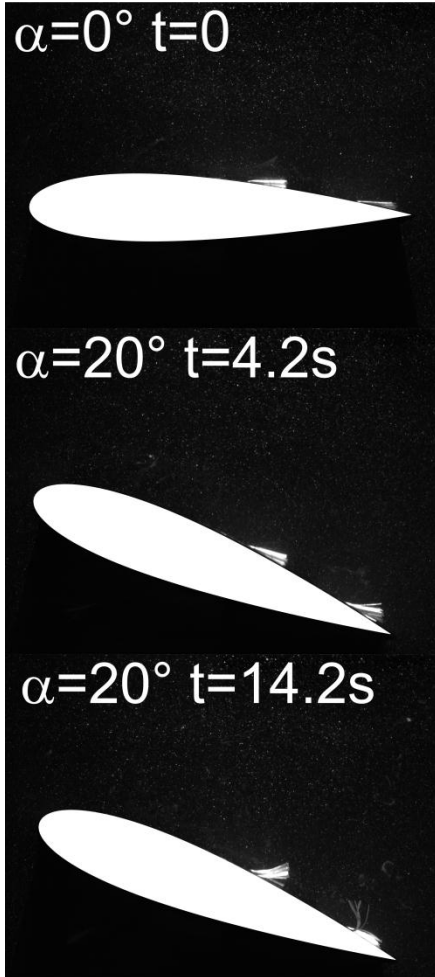

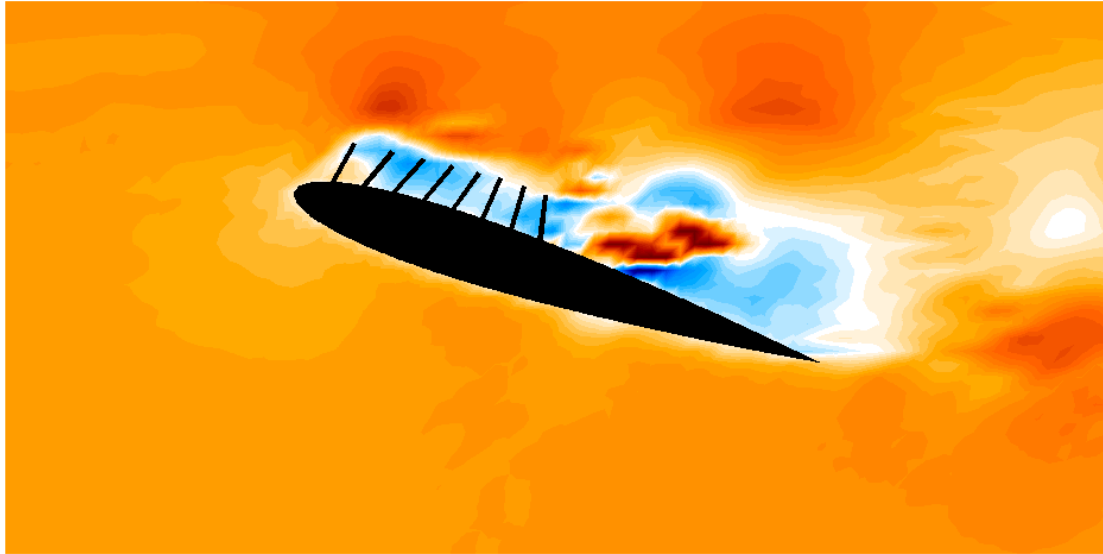

The amplitude of the oscillations decreases
(the system's stability improves) as $T_{structure} \nearrow$

(i.e. $m \nearrow$ $l \nearrow$ $K_r \searrow$)

**A parametric resonance must be triggered
to optimise the response of the system**

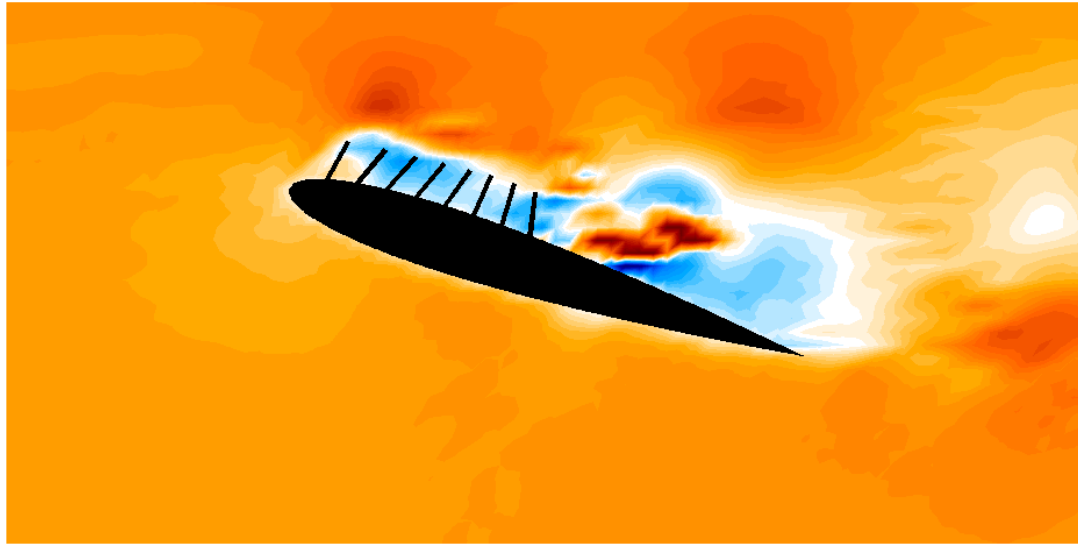

Engineering perspectives

MAV/UAV

Wind turbines

Hydraulic machines (cavitation?)

Sound mitigation



How can we increase lift over a streamlined body at incidence by a **passive** technique?

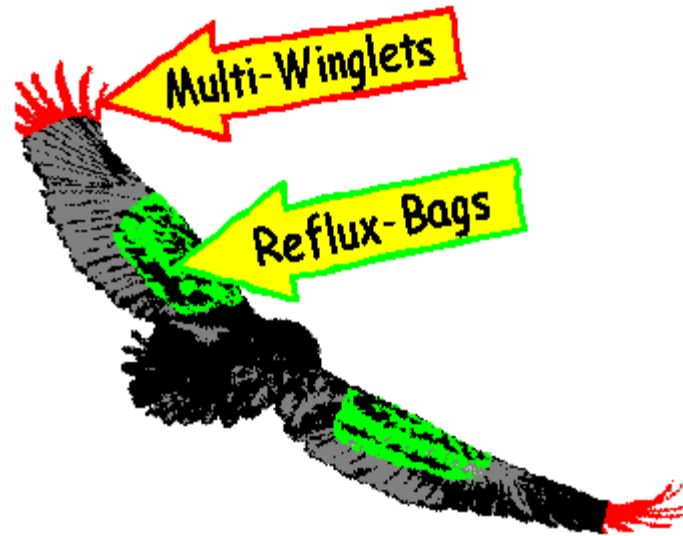

Prof. Ingo Rechenberg, TU Berlin

<http://www.bionik.tu-berlin.de/institut/xs2vogel.html>

Biomimetic winglets

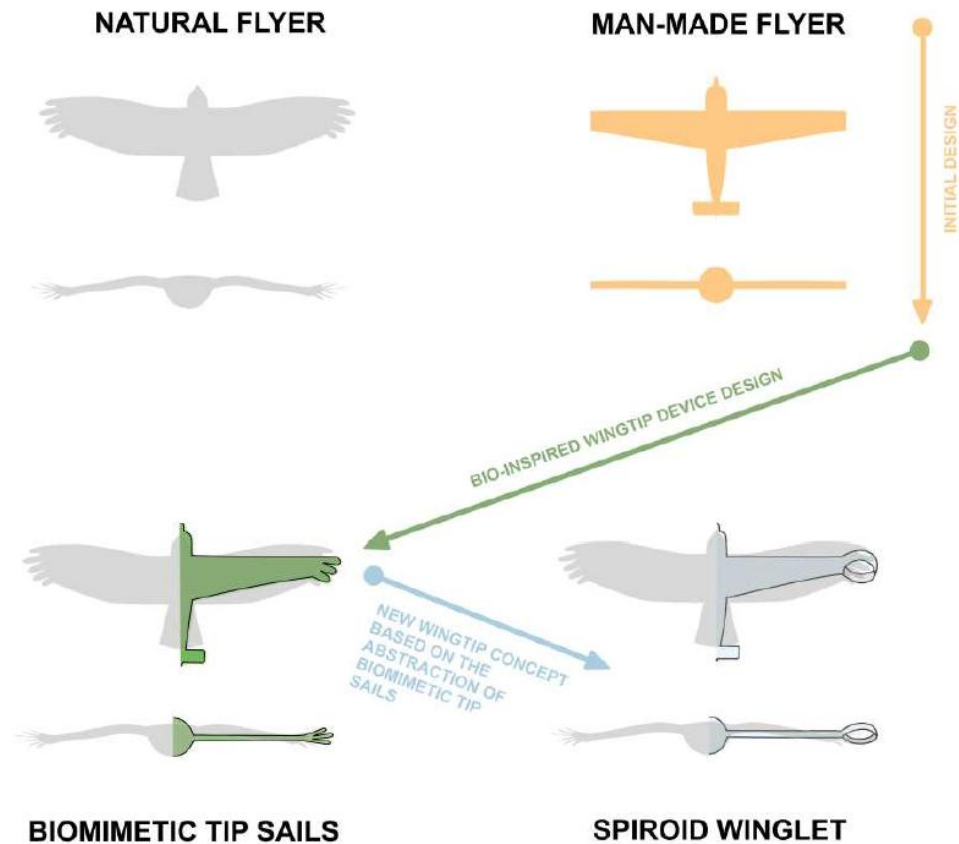

Guerrero *et al.*, **CRAS**, 2012

Biomimetic winglets

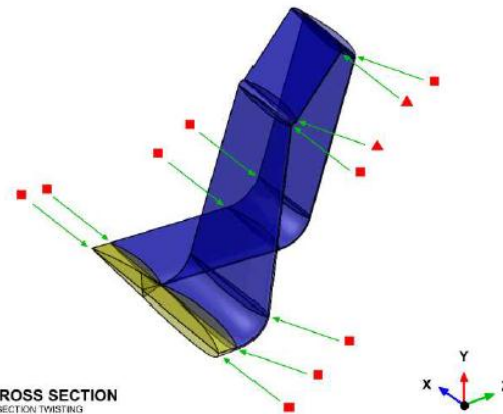
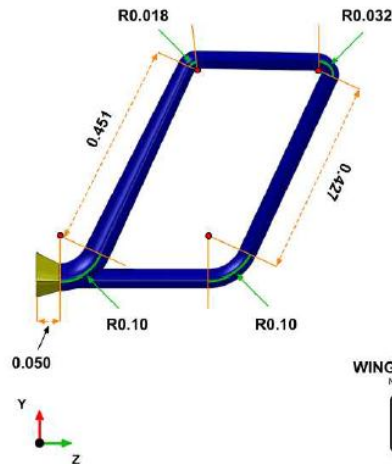
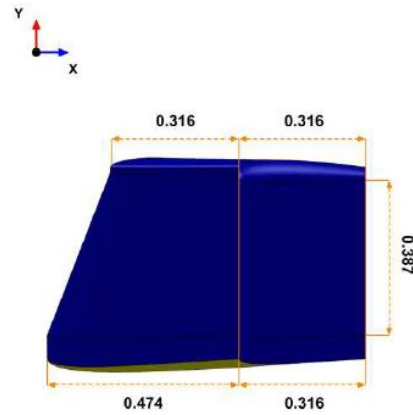
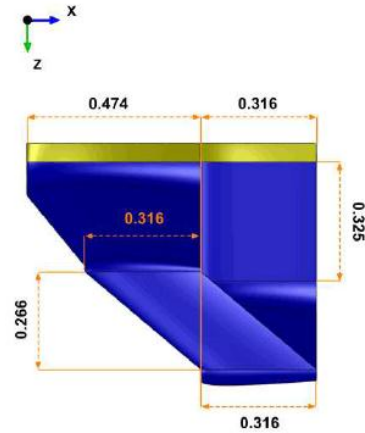

WINGLET CROSS SECTION
NO CROSS SECTION TWISTING

- NACA 2412
- ▲ NACA 0012

Biomimetic winglets

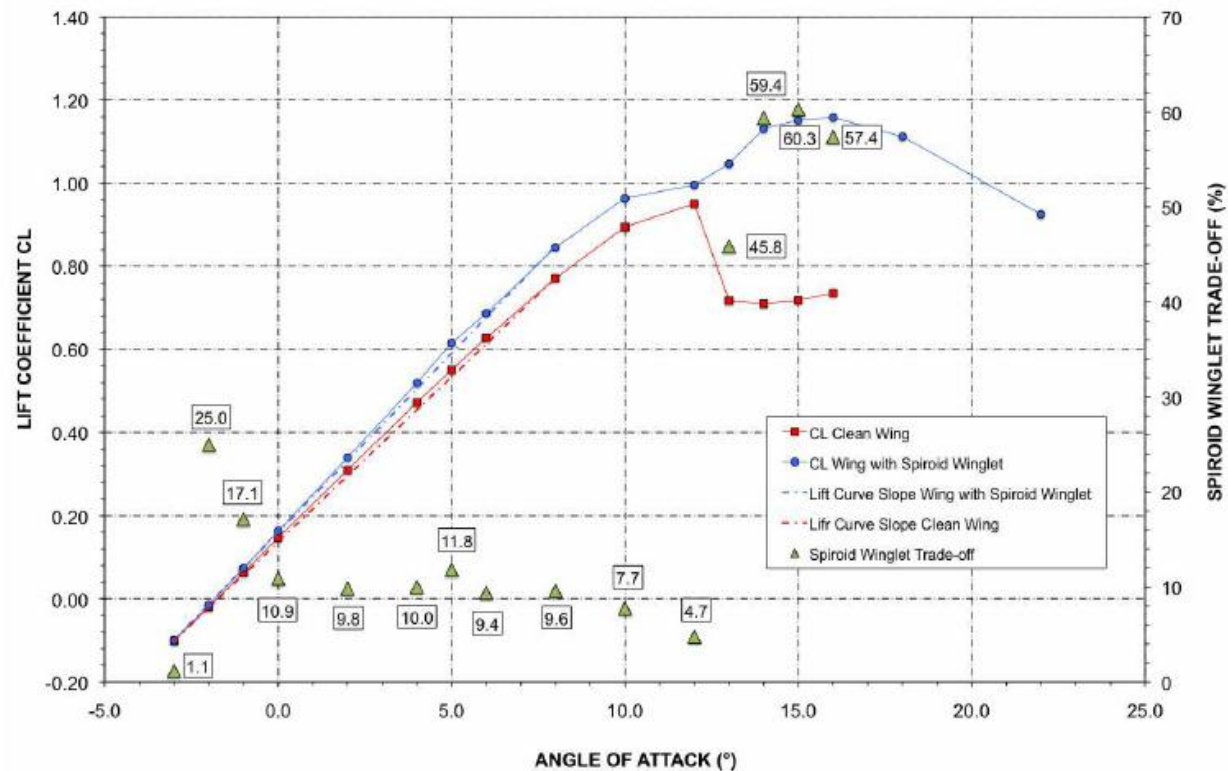

Figure 10. Lift coefficient versus angle of attack for the clean wing (CW) and the wing with the spiroid wingle (WSW).

Biomimetic winglets

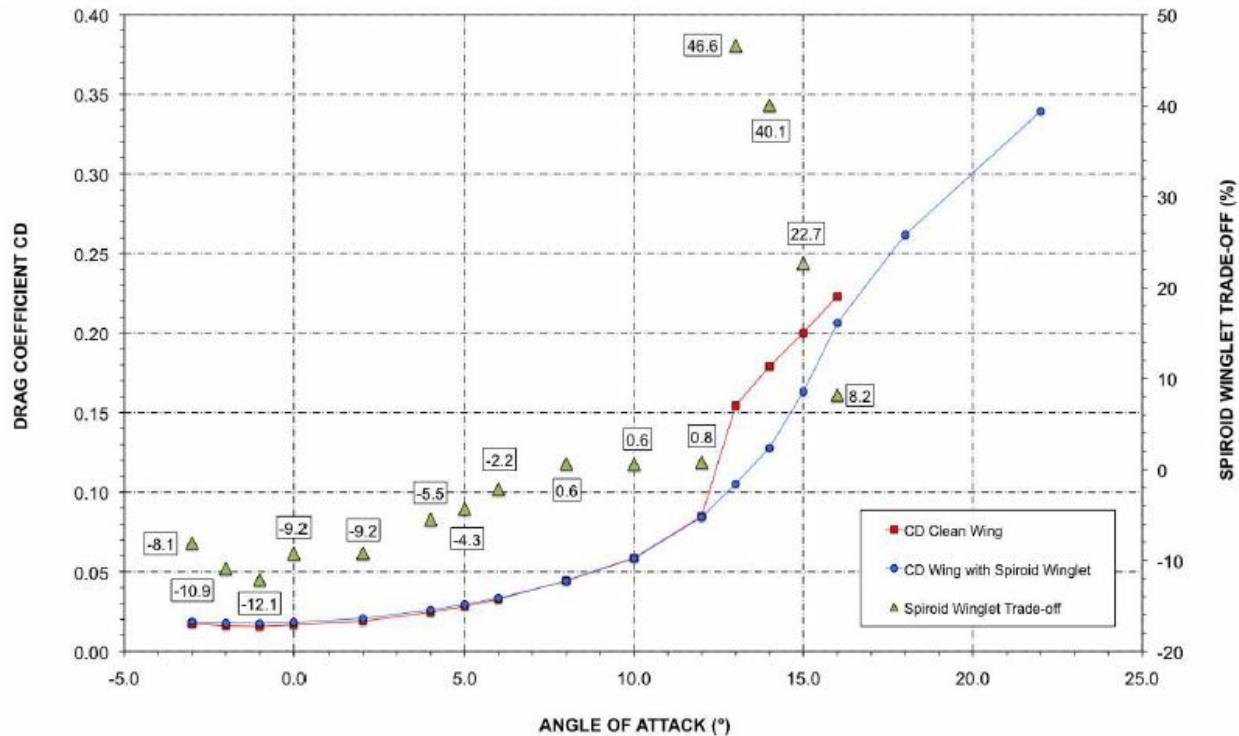

Figure 11. Drag coefficient versus angle of attack for the clean wing (CW) and the wing with the spiroid wingtip (WSW).

Biomimetic winglets

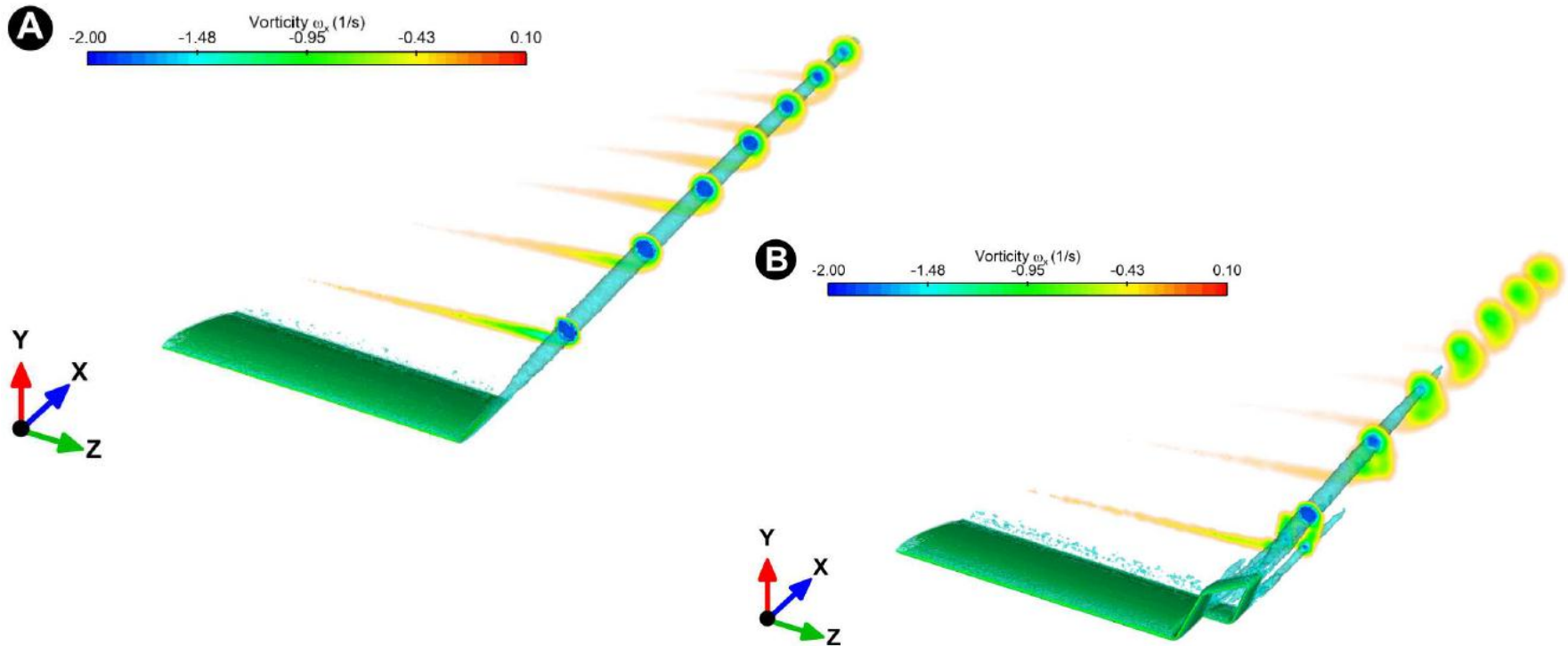

Figure 15. Wingtip vortices (in light blue), visualization by iso-surfaces of Q -criterion ($Q = 0.5 \text{ 1/s}^2$). The equally spaced planes behind the wing are colored by vorticity ω_x . A) Perspective view of the clean wing at $AOA = 5.0^\circ$. B) Perspective view of the wing with spiroid winglets at $AOA = 5.0^\circ$.

Advantages

- Lift-induced drag reduction. As much as 75.0% at $C_L = 0.95$, 35.0% at $C_L = 0.55$ and 28.0% at $C_L = 0.40$.
- Lift production enhancement. C_L is higher for the whole lift curve and its slope is increased by approximately 9.0%.
- Total drag reduction for C_L values above the crossover point $C_L = 0.47$. As much as 50.0% at $C_L = 0.95$, 20.0% at $C_L = 0.90$ and 7.0% at $C_L = 0.60$.
- Lift-to-drag ratio enhancement. The trade-off at $(C_L/C_D)_{max}$ is nearly 7.1% and the maximum trade-off value in no-stall configuration is close to 10.0% ($AOA = 8.0^\circ$).
- Wing stall delay.
- Better post-stall behavior.

... which translate into:

- Increased operating range.
- Improved take-off performance.
- Higher operating altitudes.
- Improved aircraft roll rates.
- Shorter time-to-climb rates.
- Less take-off noise.
- Increased cruise speed.
- Reduced engine emissions.
- Meet runway and gate clearance with minimal added span and height.
- Reduced separation distances and improved safety during take-off and landing operations due to wake vortex turbulence reduction.

Other biomimetics secrets currently under investigation include:

- owl silent flight



"It was just because of the surface of owl's body have a lot of coupling interaction such as special surface morphology, unique wing configuration, special internal structure and highly flexible material. They can delay the separation of turbulent boundary layer around the airfoil profile, reduce pulsating pressure of the surface of wings, and reduce the production of sound energy. Above all the feature make the surface have function of noise elimination." (Liang *et al.*, *Adv. Natur. Sciences*, 2010)

Other biomimetics secrets currently under investigation include:

- owl silent flight
- **tubercles on whale flipper, effect on stall, lift and drag ...**

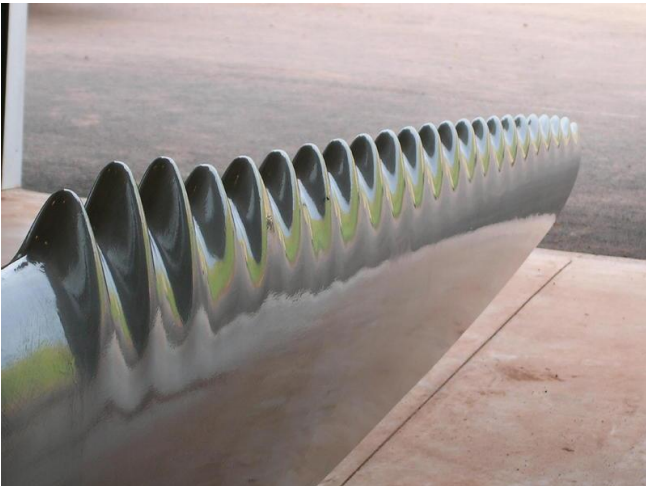

Tubercle technology!

Whalepower Corp., Canada

Other biomimetics secrets currently under investigation include:

- owl silent flight
- tubercles on whale flipper, effect on stall
- skin friction drag reduction with superhydrophobic surfaces



Leaves retain a air film underwater, using hydrophobic hairs with hydrophilic tips: 10% drag reduction in a large-scale ship model (Nees Institute, University of Bonn)

... and many others ...

Winner of 2010 EARTH AWARD

Ask Nature BETA

A project of THE BIOMIMICRY INSTITUTE

- About
- Press
- Contribute
- Browse

How would Nature...

[View all items](#)

How would a butterfly inspire your next design?

[SELF-CLEANING](#)

[PIGMENT-FREE COLOR](#)

[LOW-POWER DISPLAYS](#)

Butterflies exhibit vibrant colors and stay clean using nano-scale structures on their wings. Designers and engineers have emulated this strategy to create self-cleaning coatings, fabrics and paints, and electronic display screens. AskNature can help you solve *your* design challenges. [Learn more](#)

What's Inside?

[Discover design strategies using the biomimicry taxonomy](#)

[View one of our featured strategy slide shows](#)

[Learn about biomimicry](#)

What's New?

[AskNature launches](#)

[Looking for a new level of inspiration](#)

Follow us on [twitter](#)